

Pre-Start Ventilation System Manual

ML 513



Important Note:

It is essential for safety that the installer and user of the Expo system follow these instructions.

Please refer to the applicable standards for principles and definition.

These instructions apply only to the ventilation system. It is the responsibility of the manufacturer of the machine to provide instructions for the enclosure.

Section 1: Introduction & Application Suitability	1
Description & Use	1
Hazardous Area Classification & Certification	2
Section 2: Operation	3
Principle of Operation	3
Pre-start Ventilation Operation	4
Local Start.....	4
Remote Start (RS models).....	4
Continuous Ventilation (CV).....	4
Outlet Valve Operation.....	4
Section 3: Main Components	5
Air Supply Filter	5
Ventilation Flow Regulator.....	5
Ventilation Control Pilot Operated Regulator	5
Logic Air Supply Regulator.....	5
Electronic Timer Module.....	5
Purge Timer Power Supply	5
Visual Indicators.....	5
Terminal Box.....	6
Outlet Valve.....	6
Section 4: Installation	7
Air Supply Quality	7
Pipe Work	7
Multiple Enclosures.....	8
Power Supplies and their Isolation.....	8
Section 5: Commissioning	8
Commissioning the System	8
Increase the Ventilation Pressure.....	9
Procedure for Increasing Air Flow.....	9
Section 6: Maintenance of the System	11
General Maintenance.....	11
Maintenance of Electronic Timer System	11
Section 7: Troubleshooting / Fault Finding	12
Pre-Start Ventilation System has sufficient flow but no "System Ventilating" signal.....	13
Ventilation does not start or fails to complete	13
Ventilation Time Insufficient.....	14
Flow Sensor Calibration.....	14
Section 8: Recommended Spares List	14
Section 9: Glossary	15
Section 10: Drawings and Diagrams	15
Section 11: Certification	16
Section 12: Technical Specification	17
Model Identification.....	17
PV System Specification.....	17
Standard Options	18
Special Options	18
Outlet Valve with Integral Spark Arrestor	19

SPECIAL CONDITIONS FOR SAFE USE / CONDITIONS OF CERTIFICATE

- The intended use of this equipment is as a pre-start ventilation system. It is the user’s responsibility to ensure the correct functionality of the equipment when in use.
- The equipment enclosure may contain RTDs or simple resistive switches. It is the user’s responsibility to ensure that these are connected into suitably certified intrinsically safe circuits.
- The Pre-Start Ventilation System, low temperature version, shall be protected by a safety related system that ensures that it cannot be energised if the temperature of the air inlet or controller unit falls below -20°C. This system shall utilise the RTDs that are fitted to the control unit to provide the appropriate level of safety integrity, i.e. a level of operational safety of Cat 3 according to EN 954-1 for Category 2 (Zone 1) applications; note that these RTDs have not been assessed as a safety related device in accordance with EHSR 1.5 of the Directive 2014/34/EU.
- When the equipment is provided with an intrinsically safe solenoid valve, the user must ensure that any associated line inductance is within the parameters of the solenoid valve certificate.

Section 1: Introduction & Application Suitability

Description & Use

The Pre-Start Ventilation systems designed to protect rotating electrical machines, are certified for use in hazardous locations, where the hazardous location is non-mining (above ground) and the hazard is caused by flammable gases, or vapours. The rotating electrical machines must be rated for use within the environment of installation (with the respective markings clearly displayed).

Some High Voltage machines, although certified to “Non-Incendive” methods of protection can create incendive sparking. These sparks and “hot spots” are more likely to occur during machine startup due to the increased loading. The additional hazard that flammable gas may have entered the machine casing is the principle reason for fitting the Pre-Start Ventilation system. Refer to local standards for requirements for electrical equipment in hazardous areas.

Pre-Start Ventilation systems may be used for hazards of any gas group. Apparatus associated with the Pre-Start Ventilation system, such as intrinsically safe signalling circuits and flameproof enclosures containing switching devices may be limited in their gas group. The certification documentation supplied with any of such devices must be checked to ensure their suitability.

This system is primarily designed for use with compressed air. Where other inert compressed gases are used (Nitrogen, for example) the user must take suitable precautions so that the build-up of the inert gas does not present a health hazard. Consult the Control of Substances Hazardous to Health (COSHH) data sheet for the gas used. Where a risk of asphyxiation exists, a warning label must be fitted to the ventilated enclosure.

The following materials are used in the construction of Pre-Start Ventilation Systems. If substances that may adversely affect any of these materials are present in the surrounding environment, please consult Expo Technologies for further guidance.

Materials of Construction			
Stainless Steel	Aluminium	Acrylic	Viton/FKM
Mild (Carbon) Steel	Nylon	Silicone	
Brass	Polyurethane	Neoprene	
ABS	Polycarbonate	Polyester (glass filled)	

Note: This is NOT an Ex p “Purge & Pressurization” control system and is not designed to maintain an over-pressure within the machine casing.

Hazardous Area Classification & Certification

Standard Systems with PO

EUROPE - EXPO 13MDOC1314
IECEX - EXPO 13MDOC1313

Standard Systems with PA/PI

ExVeritas 20ATEX0717X - EN 60079-0, EN 60079-7
II 2 G Ex eb ia IIC T5 Gb Tamb -20 to +59°C
or II 2 G Ex eb ia IIC T4 Gb Tamb -20 to +60°C
or II 2 G Ex db eb ia IIC T3 or T4* Gb Tamb -60 to +60°C (LT option only)

IECEX EXV 20.0050X - IEC 60079-0, IEC 60079-7
Ex eb ia IIC T5 Gb Tamb -20 to +59°C
or Ex eb ia IIC T4 Gb Tamb -20 to +60°C
or Ex db eb ia IIC T3 or T4* Gb Tamb -60 to +60°C

ExVeritas 21UKEX1054X - EN IEC 60079-0, EN IEC 6079-7
Ex eb ia IIC T5 Gb Tamb -20 to +59°C
or Ex eb ia IIC T4 Gb Tamb -20 to +60°C
or Ex db eb ia IIC T3 or T4* Gb Tamb -60 to +60°C

INMETRO Certificate: TUV 23.0523X
ABNT NBR IEC 60079-0:2020, ABNT NBR IEC 60079-7:2018, ABNT NBR IEC 60529:2017
Ex eb ia IIC T4 Gb Tamb -20 to +60°C
or eb ia IIC T5 Gb Tamb -20 to +59°C
or Ex db eb ia IIC T3 or T4* Gb Tamb -60 to +60°C

CCC Certificate: 2022322304004721
GB/T 3836.1, GB/T 3836.2, GB/T 3836.3, GB/T 3836.4
Ex eb ia IIC T5 Gb Tamb -20 to +59°C
or Ex eb ia IIC T4 Gb Tamb -20 to +60°C
or Ex db eb ia IIC T3 or T4* Gb Tamb -60 to +60°C

* depending on heater used.

US Systems with PO option

Expo18MOC1379 - NEC 501.125(B), IEEE 1349.2011
Class I Division 2 Groups B, C and D, T4
Tamb: -10°C to +50°C
The Junction Box is rated UL Type 4 & 7

US Systems with PA/PI option

Expo17MOC####
Class I Zone 1 AEx ia IIC T4 GC
Tamb: -20°C to +60°C
The Junction Box is rated IP66 and NEMA 4X

Note: US systems must be ordered with either the RS25 or RS41 Remote Start Valve to comply with above certification.

Section 2: Operation

Principle of Operation

The Pre-Start Ventilation System applies specifically to electrical machines e.g motors and generators that are already (or in the process of) being certified/approved as increased Safety or Non Incendive for use in hazardous area.

Prior to switching on the power (either Locally or Remotely) to the electrical equipment, the machine must be ventilated to remove any flammable gas that might have entered the enclosure machine. Pre-Start Ventilation is the process of removal of contaminated air and replacement with air (or inert gas) known to be free from flammable gas prior to machine start-up. The duration of the ventilation cycle process is normally ascertained by performing a ventilation test.

The air supply can be turned off after the Ventilation Cycle has been completed. The PV system does not provide leakage compensation or maintain pressurization after the ventilation cycle.

The principle of Pre-Start Ventilation is as follows:

- Clean compressed air or inert gas is drawn from a non-hazardous location.
- The interior of the machine is pre-ventilated to remove any hazardous gas.
- Measure the flow of "ventilation air" at a defined outlet.
- Positive pressure in the enclosure of the electrical machine prevents the hazardous gas from the environment entering the machine enclosure during the ventilation cycle and presents the machine ready to start once the ventilation cycle is complete.

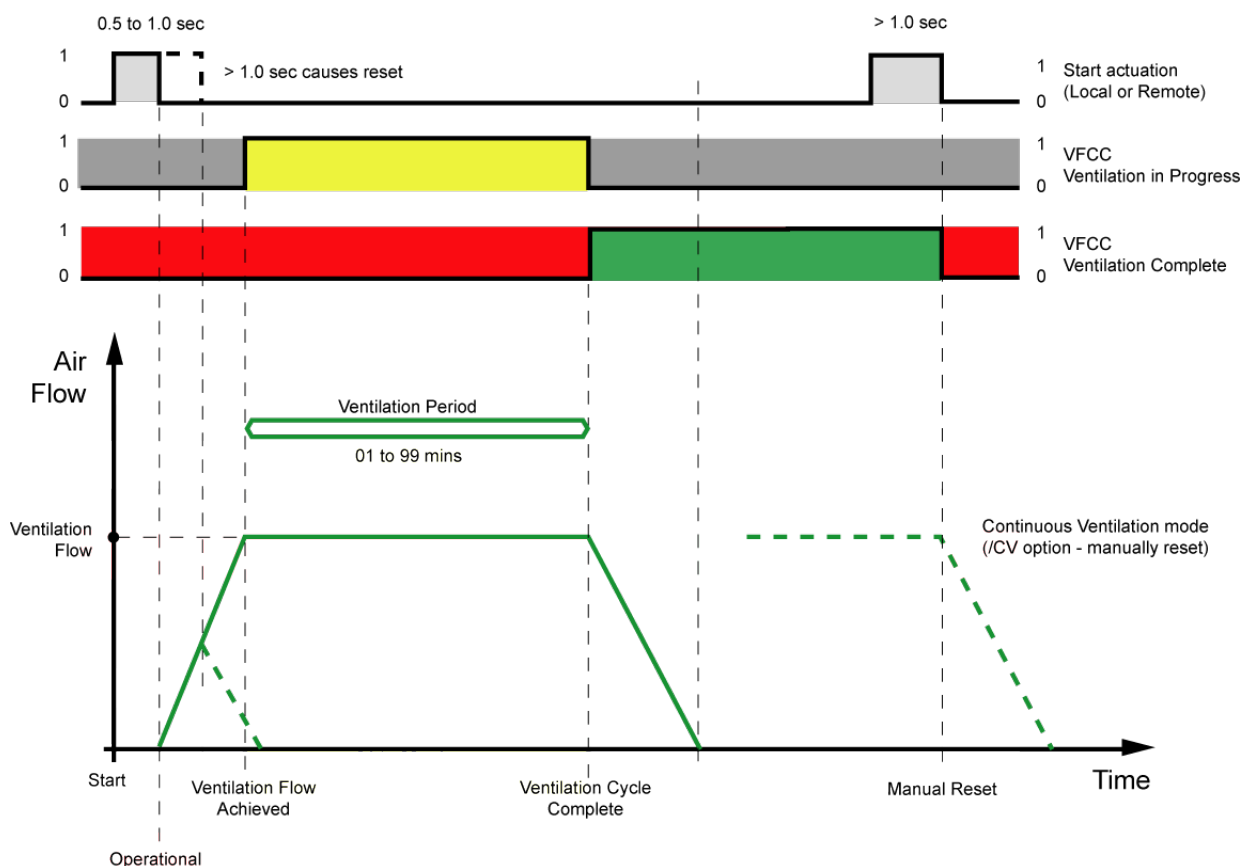

Pre-start Ventilation Operation

Turn ON the air supply, the PV system will not start until the ventilation cycle is initiated locally or remotely.

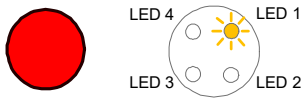

Locally or remotely energize the PV system until air flow is achieved, Once the Ventilation flow has been achieved the "System Ventilating" LED on the PV system will start flashing and also indicated externally via the System Ventilating output accordingly.

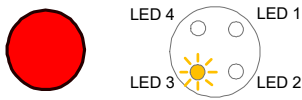

The ventilation will continue for the selected ventilation time. During this time the System Ventilating LEDs on the PV system will indicate the status of the cycle showing on the percentage of the ventilation time completed.



At the end of the ventilation time the system will turn off the air flow to the machine, the "Ventilation Complete" indicator on the PV system will show green and also be indicated externally via the Ventilation Complete output accordingly. While the system remains in ventilation complete mode, the PV system permits the switchgear to turn the motor ON. The system will remain in this mode until the system is reset or re-started, or the air supply to the system is isolated or a fault occurs.



To reset the "Ventilation Complete" signal, energize the PV system locally or remotely for one second. This will turn the motor OFF, "Ventilation Complete" indicator will show red on the front of the PV system and also indicated externally accordingly.

Note: If the PV is energized for longer than one second, the system will start a new ventilation cycle after resetting.

Local Start

All systems are fitted with a push button inside the PV enclosure to initiate a ventilation cycle, refer to the system GA drawing for the local start push button location. Push and hold the button as above instructions

Remote Start (RS models)

Remote start models are factory fitted with a solenoid valve (specified on ordering) inside the PV enclosure. This allows the PV system to be connected to an external switch/button on-site where required.

Continuous Ventilation (CV)

With the Continuous Ventilation (CV) option the ventilation flow continues, at the same flow rate, after the initial ventilation cycle has elapsed. This option permits the immediate re-start of the machine in case of machine trip.

Outlet Valve Operation

The Ventilation flow sensor in the PV system is connected to the outlet valve to measures the pressure differential across the outlet valve orifice plate. Once the pressure rises above the factory set value, the ventilating cycle will begin and the timer activated.

During Ventilation, when the pressure in the enclosure increases to the lift off pressure of the fitted Outlet Valve, the valve will automatically open to allow the ventilated gas to exit the machine enclosure through the spark arrestor. Once complete and the pressure falls, the valve will close.

Note: 7PV systems are fitted with a Pneumatically Operated Valve as standard (optional for 3PV & 5PV systems), the valve will open as flow enters the machine casing.

The outlet valve system has an Overpressure Relief Valve fitted which will also open if the pressure inside the machine rises to or above the set lift off pressure to prevent over pressurization with in the machine.

Section 3: Main Components

Refer Drawings for relevant PV system General Arrangement and components identification.

Air Supply Filter

The unit is provided with a 40-micron water / dust filter element as a precaution but air supply should be to the quality as stated in the Air Supply paragraph found in the Installation of the System section.

Ventilation Flow Regulator

The Ventilation Flow Regulator is a 0-7 barg Pressure Regulator and enables the user to adjust the total ventilation flow (between 0 to 4 barg) to the enclosure in order to achieve the required ventilation flow rate compensating for the enclosure leakage. The total ventilation flow is the (Ventilation Flow rate at the Outlet Valve +10%) + the leakage of the machine casing.

Ventilation Control Pilot Operated Regulator

This regulator controls the ventilation air supply to the enclosure according to the supply from the ventilation flow regulator and is automatically closed after the ventilation time has been completed.

Logic Air Supply Regulator

This device provides the system with a stable logic pressure supply for consistent operation. The pressure level of 4.0 barg (60 psig) is factory set and can be verified by means of the integral pressure gauge. It should only be adjusted if the gauge indicates that the regulated pressure is incorrect. This should indicate no more than 4.0 barg (60 psig). During ventilation you may notice the pressure drop down to 3.0 barg (45 psig).

Electronic Timer Module

When the ventilation flow rate has been achieved, the sensor activates the timer. The timing period is selected using switches mounted on the timer module. The Electronic Timer Module is powered either by battery or an EPPS depending on the model.

The ventilation time is indicated by for yellow LEDs on the electronic timer (see Visual Indicators).

Purge Timer Power Supply

Battery Pack - ET Models

The Electronic Timer is powered by an intrinsically safe battery pack. The battery pack should be replaced every three years. See Maintenance section.

EPPS (Electro-Pneumatic Power Supply) - ES Models



The EPPS is a flameproof/explosion proof and dust-tight module, which uses a limited amount of air from the logic system to generate sufficient intrinsically safe power to power the Electronic Timer.

When the Electronic Timer is powered by an EPPS up to 30 seconds delay is expected once the flow sensor signal is received for the timer to start.



Visual Indicators

Visual indicators are fitted to provide local status information to the operator:

Ventilation in Progress Indicator

Black		"Ventilation flow too low" (or not in Ventilation mode)
Yellow (flashing)		"Ventilation flow above the minimum" (System Ventilating)

Ventilation Complete Indicator

Red		Power Off (power to the electrical machine should be off)"
Green		Ventilation Cycle Successful (safe to apply power to the electrical machine)

Terminal Box

PA Terminal Box (Ex e)

Ex e IIC T5 Gb Ex tb IIIC T100°C Db IP66 Tamb -20°C to +55°C	Ex e IIC T4 Gb Tamb -20°C to +60°C
--	---------------------------------------

The Terminal Box is increased safety (Ex e) certified and incorporates the terminal connection points for the switches and solenoid valve (when Remote Start is included). All contacts provided are volt free (dry). Cable entry methods (for example conduit or cable glands) must be certified to IECEx and ATEX standards. The main requirement is that IP66 (or better) ingress protection must be provided by use of seals or washers.

IS Intrinsically Safe (Ex i)

The output signals "System Ventilating" and "Ventilation Complete" are available as volt-free contacts in blue terminals, for connection to Intrinsically Safe circuits. The terminal box has an isolation partition to keep the separation between I.S. circuits and non-I.S. circuits, when the solenoid valve (RS Models) is not I.S.

PO Explosion Proof Box (Ex d)

The output signals "Ventilation in Progress" and "Ventilation Complete" are 4 barg (60 psig) pneumatic signal available for connection to 1/8" NPT Female bulkheads. Connect these signals to external pressure switches.

Note: When fastening the door and gland plate for the terminal box, please ensure the bolts/screws are torqued to 6 N·m to ensure that the correct IP seal is maintained.

Outlet Valve

This device has several functions:

- The Outlet Valve unit is calibrated to open when the Ventilated Enclosure pressure exceeds the set point.
- It contains a Spark Arrestor designed to prevent the emission of arcs, sparks and incandescent particles produced by normal operation or electrical fault within the machine.
- It measures the differential pressure across the outlet orifice during ventilation flow. The measurement figure indicates when the required flow rate is achieved and timing of the ventilation cycle can start.
- It contains the overpressure Relief Valve.

To achieve effective Ventilation Flow, the point where air enters and exits the machine should normally be at opposite ends of the enclosure. The Outlet Valve unit must be mounted vertically and there should be a minimum clearance of 300 mm (12") around the spark arrestor. The Outlet Valve have user selectable orifice plates. These allow the flow rate to be selected by the user without modification to the PV system.

It is important that the interior and exterior of the spark arrestor is kept clean and debris is not allowed to accumulate. In particular the exterior of the spark arrestor should not be painted or blocked in any way.

Section 4: Installation

Warning!

- The Pre-Start Ventilation System must be installed by a competent person in accordance with relevant local standards for installation of electrical equipment and systems within hazardous areas standards.
- The Pre-Start Ventilation system should be installed either directly on, or close to the machine. It should be installed such that the system indicators and certification labels are in view.
- The system is fitted with an internal regulator factory set to 4 barg (60 psig) feeding the logic air supply regulator. The correct logic supply pressure is vital to the reliability and calibration of the Pre-Start Ventilation System, therefore should NOT be adjusted.

Air Supply Quality

- The Pre-Start Ventilation System should be connected to a protective gas supply, which is suitable for ventilation.
- The air supply must be regulated at a pressure less than the maximum stated inlet pressure.
- The air supply must be: clean, non-flammable and from a non-hazardous location. It must comply with ISO 8573-1: 2001 Class 2.2.1 or equivalent local standards. This is typically referred to as Instrument Air Quality.
- The PV system will operate with lower air quality however, the operational life of the system will be adversely affected. The equipment that is being protected by the Pre-Start Ventilation may also suffer because of poor air quality.

Instrument Air Quality

Solid Particles	0.5 μm < particle size $\leq 1 \mu\text{m}$, maximum 1000 particles / m^3
Residual Water	1 μm maximum density, +3 $^{\circ}\text{C}$ * pressure dewpoint
Oil Content	$\leq 0.01 \text{ mg}/\text{m}^3$ concentration total oil

* For applications where $T_{\text{amb}} \leq 0^{\circ}\text{C}$, the air supply should be Class 2.1.1 with humidity of -70 $^{\circ}\text{C}$ pressure dewpoint.

- The air supply must contain a dust and water filter to prevent contamination in the PV system or the ventilated equipment, not provided by Expo.
- When an inert gas is being used to supply the ventilation system, risk of asphyxiation exists. Refer to Application Suitability section.
- The ventilation air from the Pre-Started Ventilation system should be piped within the machine to ensure ventilation of potential dead air spots.

Pipe Work

- If the Pre-Start Ventilation is not connected directly to the machine enclosure, pipe work and fittings used to connect the PV system to the machine enclosure should be either metallic or appropriate to the environment into which the system is installed.
- No valve may be fitted in any signal pipe connecting the PV system to the machine enclosure. This pipe work must be fitted in accordance with local codes of practice where relevant.
- Before connecting the supply pipe to the PV System, flush with instrument quality air to remove any debris that may remain in the pipes. This must be carried out for at least 10 seconds for every metre of supply pipe.
- The size of the input pipe should be appropriate for the maximum input ventilation flow rate for the application.

- The supply/outlet pipe connections on the Pre-Start Ventilation System are dependent on what has been ordered. Below are available options, refer to system model number:

	3PV	5PV	7PV
NPTF (N)	3/4"	1"	2"
ANSI (A)	1"	1"	N/A
BSPP (B)	3/4"	1"	2"
DIN (D)	DN 20	DN 25	N/A

Multiple Enclosures

- This system is suitable for the ventilation of the primary enclosure and its associated terminal boxes.
- All parts of the system carry a common serial number. If installing more than one system, ensure that this commonality is maintained within each system installed.

Power Supplies and their Isolation

- The electrical installation must conform to the local codes of practice.
- All power entering the rotating electrical machine must have a means of isolation. This also applies to any external power sources that are connected to the equipment such as volt-free (dry) contacts within the rotating electrical machine.

Exception:

Power to Intrinsically Safe apparatus, or apparatus that is already suitable for use in hazardous locations need not be isolated by the Pre-Start Ventilation System. The installation must strictly adhere to the current standards that applies to the installation of Intrinsically Safe, Increased Safety and Type "n" apparatus.

- In all cases the user must control the application and the isolation of power to the rotating electrical machine after the Pre-Start Ventilation System shows the "Ventilation Complete" Green  signal.

Note: When fastening the door and gland plate of this enclosure, please ensure the bolts/screws are torqued to 6 N·m to ensure that the correct IP seal is maintained.

Refer to the drawings for specific system mounting, hook up and electrical connection.

Section 5: Commissioning

Commissioning the System

Refer to the General Arrangement (GA) drawing for the Pre-Start Ventilation system option/ part positioning.

If, after commissioning, the system does not perform as expected, refer to Troubleshooting.

- Disconnect the air supply pipe from the inlet to the PV System.
- Flush the pipe through with instrument quality air to remove any debris. This must be carried out for at least 10 seconds for every metre of supply pipe.
- Check all connections between the PV system and the Outlet Valve. The Outlet Valve Unit must be fitted correctly with clear path to the ventilation exhaust.
- Close and re-open the internal shut off valve.
- Check that the internal logic pressure gauge reads 4.0 barg (60 psig).

6. Start the ventilation cycle by pushing the Local Start Push Button momentarily until flow is achieved. Or use the Remote Start facility where fitted.
7. The ventilation timer will start as soon as the "System Ventilating" LED starts flashing Yellow ●.

Note: If the "System Ventilating" LED does not flash Yellow ●, this indicates low ventilation flow. This can happen with a machine housing with greater than expected leakage. Refer to "Increase the ventilation pressure"
8. Check the ventilation time matches the set time (the time between the "System Ventilating" LED starting to flash Yellow ●, and the "Ventilation Complete" indicator turning from Red ● to Green ●). The ventilation time should not be less than the set time however slightly longer times are permitted.
9. When a full ventilation cycle is successfully completed, the ventilation air flow to the machine will stop, the "System Ventilating" LEDs will turn OFF, the "Ventilation Complete" indicator will turn from Red ● to Green ● and the appropriate pneumatic or electrical signals will act accordingly.
10. The system will remain in this mode until the system is either reset or re-started, or the air supply to the system is isolated.

Increase the Ventilation Pressure.

1. Push and hold the Local Start Push Button.
2. Very slowly, open (clockwise) the Ventilation Flow Regulator, until the "System Ventilating" LED starts flashing Yellow ●.

DO NOT open too quickly as this can allow too much air and over pressurize the enclosure.
3. If after the flow regulator is fully open (the pressure gauge reads 4 mbar), and the "System Ventilating" LED does not flash Yellow ●, refer to "Procedure for increasing air flow".

Procedure for Increasing Air Flow

It is possible for the enclosure of the rotating electrical machine to have a higher leakage rate than expected, which may affect the PV system's ability to achieve sufficient air flow to start the ventilation cycle.

Note: This procedure should be carried out by a competent engineer.

Table below shows which system this procedure apply to and the flow rate achieved by removing the orifice.

System	Orifice in system Outlet Valve (required flow)	Remove Restrictor (Yes/No)
3PV	1500 NI/min	Yes
5PV	6000 NI/min	Yes
7PV	N/A	N/A

Necessary spanner (wrench) sizes

Components	3PV	5PV
Locknut	32mm	42mm
Union Nut	40mm	54mm
Union	26mm	39mm

Use the spanner (wrench) to loosen the locknut. It should go back 15 to 20mm.

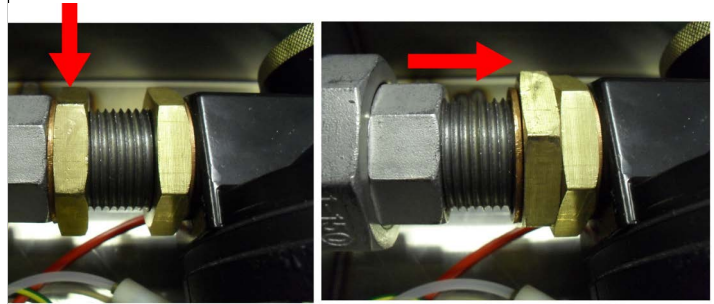

Loosen the union nut and move it back towards the locknut as shown

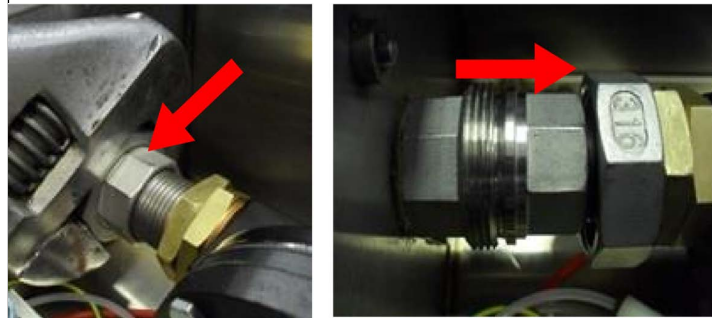

Pull the right hand half of the union back 5 to 10mm. The orifice restrictor is in the middle. Remove the restrictor.

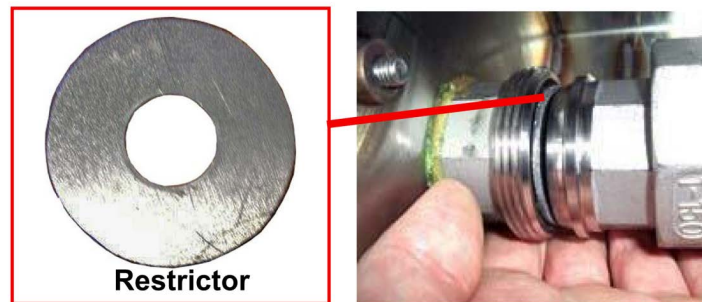

Position the halves back into position, wind and tighten the union nut.

Note: Ensure to fully tighten the nut to avoid leakage.

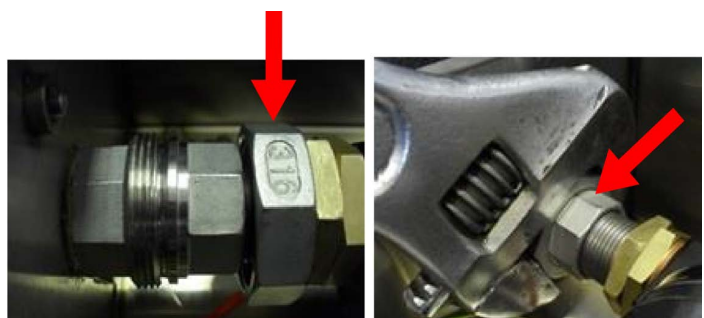

Wind back and tighten the locknut back into position.

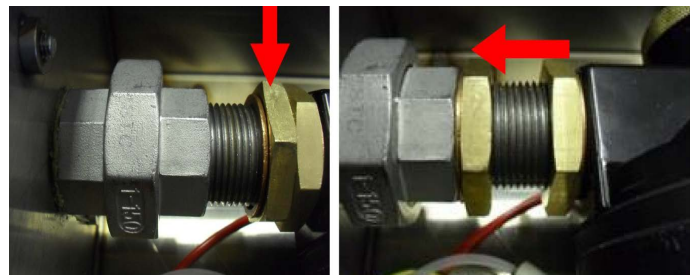

Section 6: Maintenance of the System

General Maintenance

The maintenance of the system outlined in this manual should be supplemented with any additional requirements set out in appropriate local codes of practice.

The following checks should be carried out every 6 - 36 months dependent on environment according to IEC / EN 60079-17

- Tests outlined in the Detailed Commissioning section.
- Ensure the Outlet Valve Unit is free from contamination prior to making any adjustment. To do this:
 - Remove large cover plate using a 10 mm spanner (wrench).
 - Check that the interior and all components are clean and free from contamination.
 - Replace large cover plate.
- Check the condition of the air supply filter element. Clean or replace as necessary.

The following additional checks are recommended at least every 3 years:

- Apparatus is suitable for use in the hazardous location.
- There are no unauthorised modifications.
- The air supply is not contaminated.
- The "System Ventilating" and "System Ventilation Complete" signals function correctly.
- Approval labels are legible and not damaged.
- Adequate spares are carried.
- The action on pressure failure is correct.

Maintenance of Electronic Timer System

ET Models - This must be carried out every 3 years.

- The battery may be hot-swapped in the hazardous location without affecting the operation of the Pre-Start Ventilation System. The Battery **MUST NOT** be replaced during a ventilation.
- After replacement, repeat the commissioning tests.
- The battery module should be disposed of in accordance with the battery's Material Safety Data Sheet and any relevant local and national directives.

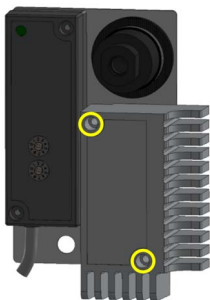

Use a flat head screwdriver to loosen and remove the two retaining screws from the battery pack.

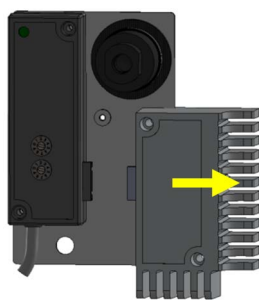

Pull the battery module away from the e-timer to unplug the battery from the e-timer.

WARNING! Pulling at an angle could break the E-timer connector.



Insert the screws and washers into the new battery module.

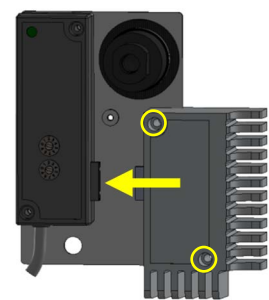

Fully plug the new battery module into the e-timer.

ES Models

- The EPPS is intended to be maintenance free. However, routine inspection of the electrical and pneumatic connections is required to ensure safe operation. Check that the exhaust port on the EPPS is not obstructed, and firmly secured to the base plate.
- The EPPS should not be opened. Any modifications on the EPPS will invalidate the certificate.

Section 7: Troubleshooting / Fault Finding

- If the problem is not resolved after following the below instructions, please contact Expo or your local supplier for further assistance.
- If the system is less than 12 months old, parts under warranty should be returned to Expo for investigation. A full report of the fault and the system serial number should accompany the parts.
- It is common for problems with the Pre-Start Ventilation System to be caused by contamination of the air supply with oil, water or dirt. Ensure the air supply is fitted with both a dust and water filter (must be sourced separately).
- Contamination can enter the system from a number of sources. To prevent this, it is essential that the procedures described in the Installation section are carried out prior to first use of the system. These procedures should also be carried out following any disconnection and re-connection of the pipe work. Failure to perform these procedures may cause damage to the system that will not be covered by the warranty.
- The system has been designed for ease of fault finding and the many of the components fitted are plug-in or chassis mounted. Check components by substitution only after establishing that such action is necessary.

Before carrying out detailed fault finding procedures, ensure that:

- Both the main air pressure to the system and the regulated pressure to the logic manifold are as specified on the settings sheet.
- Air pressure does not drop below the minimum supply pressure during ventilation; the majority of faults reported are due to insufficient air supply during the ventilation cycle.

Pre-Start Ventilation System has sufficient flow but no “System Ventilating” signal.

Fault Location	Cause	Solution
Battery Pack (ET Model)	The battery pack is discharged.	<ul style="list-style-type: none"> • Battery needs replacement. Consult Expo Technologies.
“System Ventilating” switch.	Stroke actuator faulty. Ex d system ventilating switch is faulty.	<ul style="list-style-type: none"> • Check the actuation of switch by the “Short Stroke Actuator for Ex d Switch”. Refer to relevant General Arrangement (GA) drawing. • If Stroke Actuator is not moving while the system is ventilating, the actuator may require replacement. Consult Expo Technologies. • If Stroke Actuator is working, check that the switch is closing. • If it is not closing, it needs to be replaced. • If it is closing but no signal is present, the switch needs replacement. Consult Expo Technologies

Fault Location	Cause	Solution
Electronic Timer	The Electronic Timer is faulty	<ul style="list-style-type: none"> Needs replacement. Consult Expo. <p>This should be done by a competent Service Engineer.</p>

Ventilation does not start or fails to complete

This is common due to the smaller pipe diameter or smaller compressor.

Fault Location	Cause	Solution
Air Supply Pressure	Air supply pressure fall below 4 barg (60 psig).	<ul style="list-style-type: none"> Check that the air supply pressure is not below the specified minimum pressure during ventilation. Increase air pressure. The pressure gauge should be above 4 barg (60 psig) during ventilation. or replace main air filter. Consult Expo Technologies.
Machine could have a greater leakage rate than expected	Insufficient air supply to rotating electrical machine enclosure.	<ul style="list-style-type: none"> Slowly turn the Ventilation Flow Regulator to increase the air flow. Do this until the "Ventilation in Progress" indicator is activated. Indicator should turn from "Black ●" to "Flashing Yellow ●" This indicates correct Ventilation Flow. If the problem is not solved, refer to the "Procedure for increasing air flow" in the Commissioning section.
Remote Solenoid Valve	Not functioning	<ul style="list-style-type: none"> Check all connections from the PV system to the Remote Start control, continuity and supply voltage where possible. Make sure all connections are secure and terminated correctly. If all these appear to be correct, then check the operation of the system by using the Local Start Push Button. If the Local Start Push Button successfully starts a ventilation cycle, the Solenoid Valve needs replacement.
Electronic Timer Power Supply	Battery is not working correctly EPPS not working correctly	<ul style="list-style-type: none"> Battery may need replacing. Check all connections to and from the EPPS. Check the external exhaust port is free of debris and obstructions. EPPS may need replacing

Ventilation Time Insufficient

Fault Location	Cause	Solution
Electronic Timer Selector Switch	Not set correctly Electronic Timer is faulty	<ul style="list-style-type: none"> Make sure the Electronic Timer Selector Switch is correct to the required setting. Replacement necessary This should be fitted by a competent Service Engineer.

Flow Sensor Calibration

Contact Expo Technologies for new Ventilation Flow Sensor if the sensor is out of calibration.

Section 8: Recommended Spares List

Part Number	Description
General Spares	
HF1-A03N-008	Filter kit for HF1-A03N-009 filter - size 3
HF1-A03N-007	Filter kit for HF1-A03N-006 filter - size 5
HF1-A03N-002	Filter kit for HF1-A03N-001 filter - size 7
S0030/606	Ventilation Flow sensor, must be factory set to the value as stated on the Customer Test and Inspection Sheet
Terminal Spares	
S0191/025	Ex d II switch SPCO
AGE-SW0Z-035	IS switch SPCO
Timer Spares	
ETM-IS31-001	IS battery pack for Electronic Timer (ET Models)
EPW-EPPS-000	EPPS 10.8V 80mA for Electronic Timer (ES Models)
Remote Start Spares	
KPV-RS01	24VDC Remote Start Solenoid Kit
KPV-RS02	110VAC Remote Start Solenoid Kit
KPV-RS03	230VAC Remote Start Solenoid Kit
KPV-RS11	24VDC (IS) Remote Start Solenoid Kit
KPV-RS24	24VDC (Ex d) Remote Start Solenoid Kit

Section 9: Glossary

Acronym	Definition
PV	Pre-Start Ventilation system
EPPS	Electro-Pneumatic Power Supply
ES	Electronic Timer powered by EPPS
ET	Electronic Timer powered by battery
LS	Local Start Pushbutton
RS	Remote Start (Solenoid valve)
IS	Intrinsically Safe

Acronym	Definition
PA	Permissive Alarm
OV	Pneumatically Operated Outlet Valve
PO	Pneumatic Output

Section 10: Drawings and Diagrams

Title	Drawing Number	Number of Sheets
Standard Ventilation System (PA/IS Option)		
Size 3 Pre-Start Ventilation System	XBR-1TD0-015	2
Size 5 Pre-Start Ventilation System	XBR-1TD0-014	2
Size 7 Pre-Start Ventilation System	XBR-1TD0-016	2
Ventilation System (PO Option)		
Pre-Start Ventilation System 3pv	3PV-SS-RS41-N-ET-PO-US	2
4X 3PV/SS/RS24/N/ET/PO/US	4X 3PV SYSTEM	2
4X 5PV/SS/RS24/N/ET/PO/US	4X 5PV SYSTEM	2
Outlet Valve		
RLV52 Outlet Valve (3PV System)	XBR-1TD0-015	1
5PV RLV (5PV System)	XBR-1TD)-014	1
Size 7 Motorpurge RLV with Lifting Eyebolts	XBR-1TD0-016	1
Hook Up/General System Installation		
3/5PV Hook Up Diagram	PV-HU	1
3PV-PO Hook Up Diagram	3PV-PO-HU	1
7PV Hook Up Diagram	7PV-HU	1
PRESTART SYSTEM P & I DIAGRAM	PV-PI	1
PO PRESTART SYSTEM P & I DIAGRAM	3PV-PO-PI	1
Terminal Box/Connections		
Ex E Junction Box Layout	AGE-WC00-230	1
Nema 4X, IP66 Junction Box - I.S. Terminal Layout	AMU-D1S4-011	1
Pre-Ventilation System Terminal Layout	AGE-WC00-273	1
Pre-Ventilation Po System Schematic	AGM-PA00-152	1
3PV 5PV 4x US Option Terminal Layout	AGE-WC00-340	1
Indicator Displays/Switch Sequence	SD8100	1

Section 11: Certification

Certificates can be downloaded at www.expoworldwide.com.

Component	Certificate	Number
Ventilation System	EU Declaration of Conformity	SC024*
	ATEX Certificate	ExVeritas 20ATEX0717X
	IECEX Certificate	IECEX EXV 20.0050X
	INMETRO Certificate	TÜV 23.0523X
	CCC Certificate	2022322304004721
	Expo Declaration (US option)	Expo 17MDOC####
	Expo Declaration (US option)	Expo 18MDOC1379
MIU/e Ex e Terminal Box	EU Declaration of Conformity	SC027*
	ATEX Certificate	ExVeritas 19 ATEX0542X
	IECEX Certificate	IECEX EXV 19.0057X
	CCC Certificate	2020312303000422
Explosion Proof Box	UL Listing	E344596
Electronic Timer	EU Declaration of Conformity	SC039*
	ATEX Certificate	FM 10ATEX0003X
	IECEX Certificate	IECEX FME 10.0001X
Electronic Switches	ATEX Certificate	EPS 14ATEX1766 X
	IECEX Certificate	IECEX EPS 14.0092X
	CCC Certificate	2020322304000843
	Expo Declaration (IS option only)	Expo 20MDOC1391X
RTDs	Expo Declaration (LT option only)	Expo 20MDOC1403X
Solenoid Valve	Certificate number as per solenoid supplied	

*Documents are attached to the manual.

Section 12: Technical Specification

Model Identification

Enclosure / Type*	System / Size	Enclosure / Material	Starting / Mode	Inlet/Output / Connection	Timing / Method	Output / Signals	Other / Options
Example:	3PV	/ ss	/ RS01	/ N	/ ET	/ PA	

* 4X for MENA 4X models only, otherwise blank

PV System Specification

	3PV	5PV	7PV
Flow Rate Capacity	500 to 1500 NI/min	2000 to 6000 NI/min	7000 to 14000 NI/min
Selectable Flow rates	500, 1000, 1500 NI/min	2000, 3000, 4000, 5000, 6000 NI/min	7000, 8000, 10000, 12000, 14000 NI/min
Default flow rates ¹	1000 NI/min	2000 NI/min	7000 NI/min

		3PV	5PV	7PV
Flow rate tolerance		-0 to +20%	-0 to +20%	-0 to +20%
Flow Sensors		Factory set to match required flow rate		
Supply Pressure	Standard Supply	4 to 10 barg (60 to 145 psig)		
	High Supply (HS)	N/A	4 to 16 barg (60 to 232 psig)	4 to 16 barg (60 to 232 psig)
Compressed Air Supply		Clean, dry, oil free air or inert gas to instrument quality		
Logic Regulator & Gauge		Factory set to 4 barg (60 psig)		
Air consumption		<10NL/min when not in ventilation mode		
Ventilation Time		User selectable Up to 99 mins (-0 to +3 s)		
Indicators	System Ventilating	Black (LEDs OFF) ●: Standby LED Flashing Yellow ●: System Ventilating		
	Ventilation complete	Red ●: Not ventilating Green ●: Ventilation Complete		
Pneumatic Signals	System Ventilating	4 barg (60 psig) - 1/8" NPTF fitting (plug fitted)		
	Ventilation Complete	4 barg (60 psig) - 1/8" NPTF fitting (plug fitted)		
Enclosure Material		316 Stainless Steel		
Mounting Method		Wal mounting straps & spacers. Fix holes as per drawings		
System Dimensions		Refer to model drawings for detailed dimensions		
System Weight ²		16.5 kg (36.3 lb)	20.6 kg (45.4 lb)	43 kg (154 lb)

1. Systems shipped with the default flow rate unless specified from the customer prior to shipping. Refer to the system label for unit set flow rate.
2. Weights are for standard models with a standard terminal box. Weights of special variants and different terminal boxes will vary. Refer to system GA for model specific weights.

Standard Options

		3PV	5PV	7PV
Starting Mode	Local Start (LS)	Internal Push Button		
	Remote Start (RS)	Internal Solenoid valve - options:* EX mb: 24 Vdc / 115 Vac / 230 Vac EX i: 24 Vdc EX d: 24 Vdc / 115 Vac / 230 Vac		
Inlet/outlet Air Connection	NPTF (N)	3/4"	1"	2"
	ANSI (A)	1"	1"	N/A
	BSPP (B)	3/4"	1"	2"
	DIN (D)	DN 20	DN 25	N/A
Timing Method	ET Option	Electronic Timer with internal battery power supply		
	ES Option	Electronic Timer Powered with electro-pneumatic power supply		

* Consult Expo if another voltage or specific certification is required.

		3PV	5PV	7PV
Output Signals				
IS option	System Contacts	SPCO switch, contact ratings 24 Vdc 4 Amps, considered to be 'simple apparatus' in intrinsically safe circuits (by others)		
	Terminal Box	Stainless steel, for intrinsically safe circuits only, c/w blue terminals, front access cover and lower removable gland plate. IP66.		
PA option	System Contacts	SPCO switch, contact ratings 250 Vac 4 Amps (AC-15) / 24 Vdc 4 Amps, Ex d IIC T6 Gb / Ex tb IIIC T80°C Db.		
	Ex e Terminal Box	Stainless Steel, with terminals, front access cover & lower removable gland plate. Ex e IIC T5 Gb / Ex tb IIIC T100oC Db IP66 Tamb : -20 to +55oC Ex e IIC T4 Gb Tamb : -20 to +60oC		
PO option	System Contacts	2 barg / 30 psi / 200Kpa UL, CSA & IEC: 6A 125Vac / 3A 250Vac		
	Ex d / Explosion Proof Box	Aluminium, IP66 box Ex db IIC T6 Gb Tamb : -20 to +40 °C Ex db IIC T5 Gb Tamb : -20 to +55 °C UL Type 7 box suitable for Class I Division 1 Groups B, C & D.		
	4X Bartec FN Box	Class I, Division 1 Groups BCD Enclosure Type 4X		

Special Options

	3PV	5PV	7PV
Continuous Ventilation (CV)	Ventilation sustained indefinitely after completion of ventilation cycle		
Low Temperature (LT)	Low Temperature option - Operates down to -60°C		
Pneumatic Output Valve (PV)	Outlet valve, pneumatically operated		Standard in 7PV systems
Systems for use in America (US)	NEC Class 1, Division 2 compatible		

Outlet Valve with Integral Spark Arrestor (contains over pressure relief valve)

		3PV	5PV	7PV
Model number		RLV052/ss/PV	RLV104/ss/PV	RLV200/ss/PV/OV
Outlet Valve Lift off Pressure		15 mbarg (6" wg)	15 mbarg (6" wg)	Pneumatically Operated
Over pressure Relief Valve Lift off Pressure	Minimum	20 mbarg (8" wg)	20 mbarg (8" wg)	20 mbarg (8" wg)
	Maximum	50 mbarg (20" wg)	50 mbarg (20" wg)	50 mbarg (20" wg)
	Default	30 mbarg (12" wg)	30 mbarg (12" wg)	30 mbarg (12" wg)
	Tolerance	-0 to +20%	-0 to +20%	-0 to +20%
Unit Weight		4 kg (8.8 lb)	7 kg (15.4 lb)	25 kg (50.6 lb)

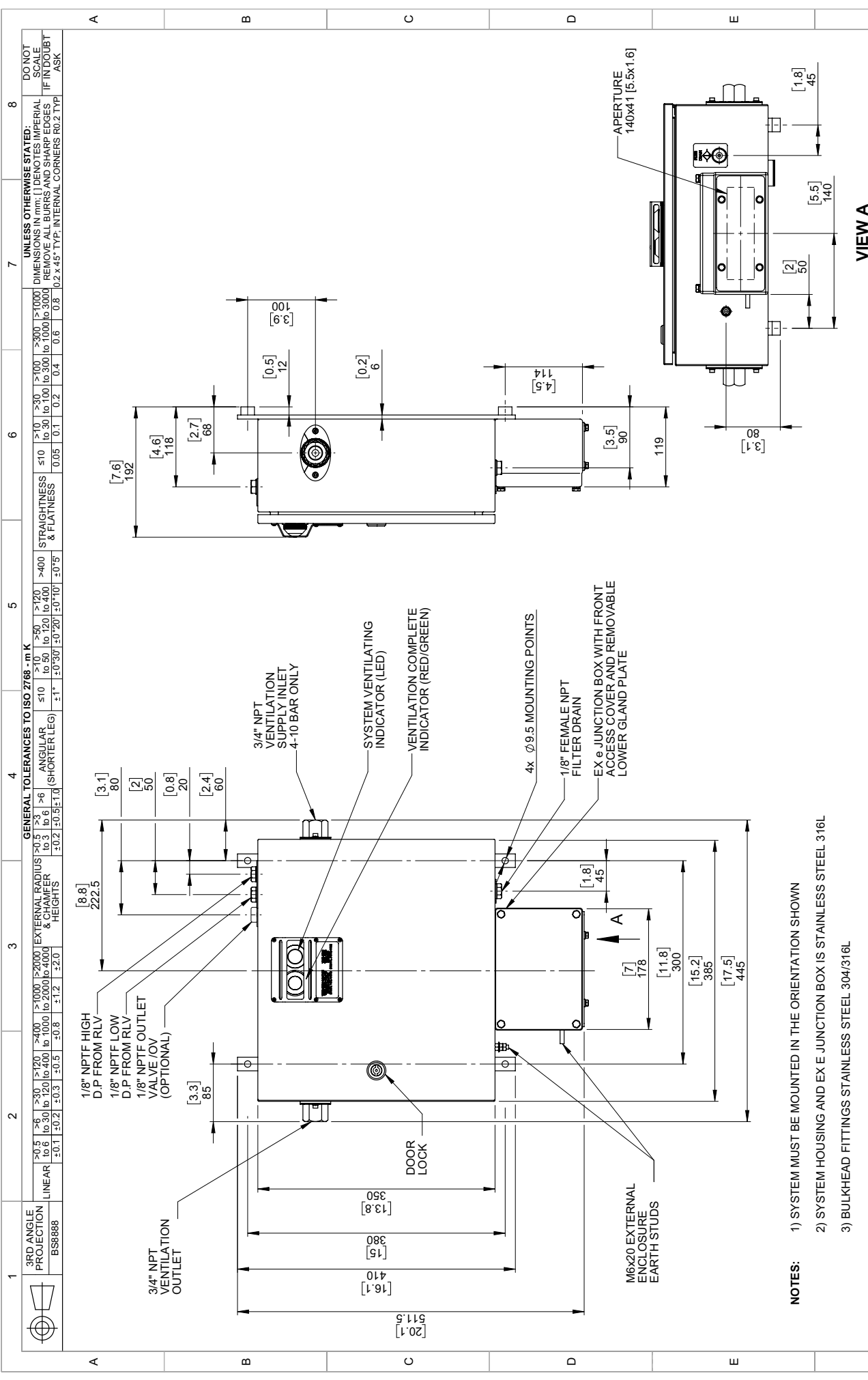

3RD ANGLE PROJECTION BSB888		GENERAL TOLERANCES TO ISO 2768 - m K LINEAR: >0.5 to <0.5: ±0.1, >0.5 to <1.0: ±0.2, >1.0 to <3.0: ±0.3, >3.0 to <6.0: ±0.6, >6.0 to <30.0: ±1.0, >30.0 to <100.0: ±1.5, >100.0 to <300.0: ±2.0, >300.0 to <1000.0: ±3.0, >1000.0 to <3000.0: ±5.0, >3000.0 to <10000.0: ±10.0 ANGULAR (SHORTER LEG): >10 to <30: ±0.5, >30 to <60: ±1.0, >60 to <120: ±1.5, >120 to <200: ±2.0, >200 to <400: ±3.0, >400 to <1000: ±5.0, >1000 to <3000: ±10.0, >3000 to <10000: ±20.0 STRAIGHTNESS & FLATNESS: <10: 0.05, <10 to <30: 0.1, <30 to <100: 0.2, <100 to <300: 0.4, <300 to <1000: 0.6, <1000 to <3000: 1.0, >3000 to <10000: 2.0 DO NOT SCALE IF IN DOUBT ASK		DRAWING NO. XBR-1TD0-015 LIFE/CYCLE STATE: RELEASED REVISION: 08		DRAWING TYPE: GENERAL ASSEMBLY SCALE: 1:5 SIZE: A3 SHEET: 1/3	
TITLE: SIZE 3 PRE-START VENTILATION SYSTEM		MATERIAL: SEE PART DETAILS FINISH: SEE PART DETAILS COMPLIANCE REQUIRED: REACH, RoHS & 3TG <input checked="" type="checkbox"/> SCHEDULE DOC. REF <input checked="" type="checkbox"/>		MASS (kg): 14.6 ML645 - PV Systems		EXPO Technologies Ltd. owns the copyright on this document and all rights are reserved. This document should be treated as confidential; it must not be used for any purpose other than that for which it is supplied, and must not be copied in whole or in part, or any part thereof, without the prior written consent of EXPO Technologies Ltd. A copy of this document made by any method must also contain a copy of this legend.	
REVISION: 08 DRAWN: BA CHECKED: AO APPROVED: SH DATE: 30/01/2024		REVISION: 07 DRAWN: CE CHECKED: RJ APPROVED: AR DATE: 07/05/2020		REVISION: 06 DRAWN: CE CHECKED: RJ APPROVED: PB DATE: 07/05/2020		EXPO Technologies Ltd. owns the copyright on this document and all rights are reserved. This document should be treated as confidential; it must not be used for any purpose other than that for which it is supplied, and must not be copied in whole or in part, or any part thereof, without the prior written consent of EXPO Technologies Ltd. A copy of this document made by any method must also contain a copy of this legend.	

- NOTES:**
- 1) SYSTEM MUST BE MOUNTED IN THE ORIENTATION SHOWN
 - 2) SYSTEM HOUSING AND EX E JUNCTION BOX IS STAINLESS STEEL 316L
 - 3) BULKHEAD FITTINGS STAINLESS STEEL 304/316L

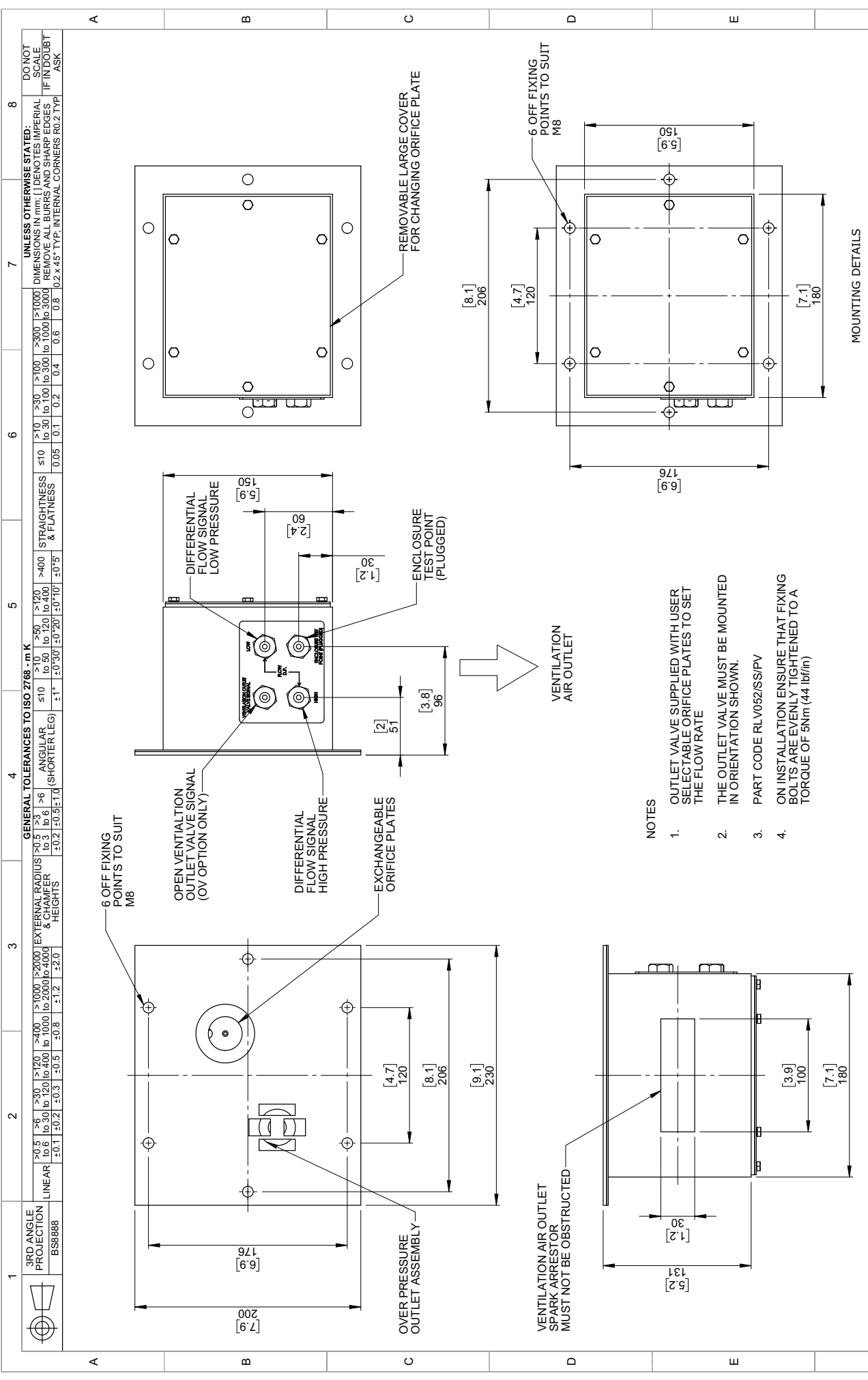

NOTES

1. OUTLET VALVE SUPPLIED WITH USER SELECTABLE ORIFICE PLATES TO SET THE FLOW RATE
2. THE OUTLET VALVE MUST BE MOUNTED IN ORIENTATION SHOWN.
3. PART CODE RLV052/SS/PV
4. ON INSTALLATION ENSURE THAT FIXING BOLTS ARE EVENLY TIGHTENED TO A TORQUE OF 5Nm (44 lbf/in)

MOUNTING DETAILS

REVISION		DRAWING NO.		TITLE		DRAWING TYPE		SCALE		SHEET	
08	24/025	BA	AO	SH	30/01/2024	XBR-1TD0-015		RLV52 OUTLET VALVE		GENERAL ASSEMBLY	
07	06/064	CE	RJ	AR	07/05/2020	RELEASED		08		1:10	
06	06/064	CE	RJ	PB	07/05/2020	RELEASED		08		1:10	
ECR No.		DRAWN		CHECKED		APPROVED		DATE		SHEET	
24/025		BA		AO		SH		30/01/2024		3/3	
DON-12423		CE		RJ		AR		07/05/2020		A3	
06/064		CE		RJ		PB		07/05/2020		A3	
MATERIAL		FINISH		COMPLIANCE REQUIRED		REACH		ROHS & 3TG		SCHEDULE DOC. REF	
SEE PART DETAILS		SEE PART DETAILS		ML645 - PV Systems		REACH		ROHS & 3TG		SCHEDULE DOC. REF	
MASS (kg)		4.0		ML645 - PV Systems		REACH		ROHS & 3TG		SCHEDULE DOC. REF	
4.0		ML645 - PV Systems		REACH		ROHS & 3TG		SCHEDULE DOC. REF		SCHEDULE DOC. REF	
4.0		ML645 - PV Systems		REACH		ROHS & 3TG		SCHEDULE DOC. REF		SCHEDULE DOC. REF	



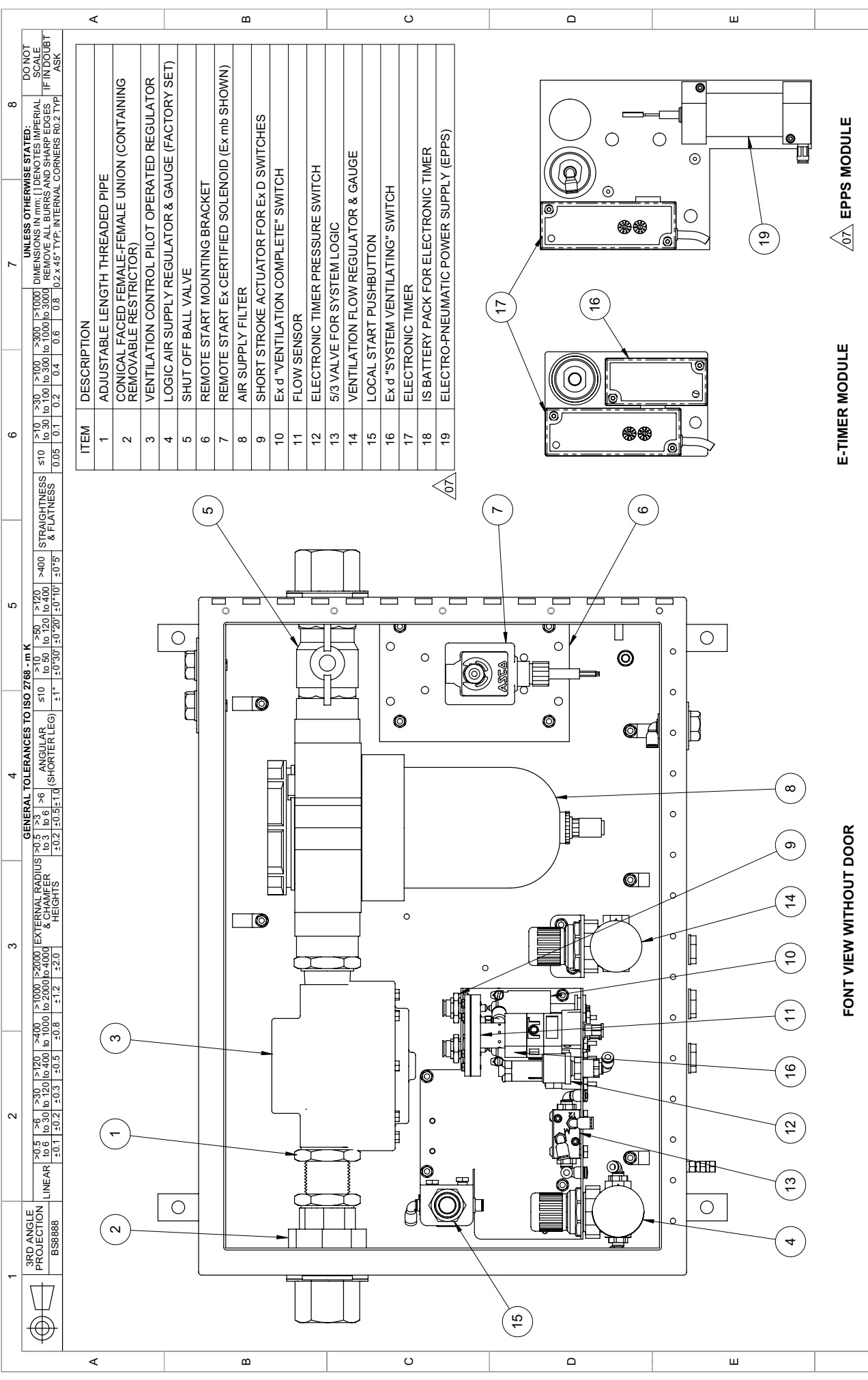

ITEM	DESCRIPTION
1	ADJUSTABLE LENGTH THREADED PIPE
2	CONICAL FACED FEMALE-FEMALE UNION (CONTAINING REMOVABLE RESTRICTOR)
3	VENTILATION CONTROL PILOT OPERATED REGULATOR
4	LOGIC AIR SUPPLY REGULATOR & GAUGE (FACTORY SET)
5	SHUT OFF BALL VALVE
6	REMOTE START MOUNTING BRACKET
7	REMOTE START Ex CERTIFIED SOLENOID (Ex mb SHOWN)
8	AIR SUPPLY FILTER
9	SHORT STROKE ACTUATOR FOR Ex D SWITCHES
10	Ex d "VENTILATION COMPLETE" SWITCH
11	FLOW SENSOR
12	ELECTRONIC TIMER PRESSURE SWITCH
13	5/3 VALVE FOR SYSTEM LOGIC
14	VENTILATION FLOW REGULATOR & GAUGE
15	LOCAL START PUSHBUTTON
16	Ex d "SYSTEM VENTILATING" SWITCH
17	ELECTRONIC TIMER
18	IS BATTERY PACK FOR ELECTRONIC TIMER
19	ELECTRO-PNEUMATIC POWER SUPPLY (EPPS)

07 EPPS MODULE

E-TIMER MODULE

FONT VIEW WITHOUT DOOR

REVISION	ECR No.	DRAWN	CHECKED	APPROVED	DATE	DRAWING No.	TITLE	DRAWING TYPE	SCALE	SIZE	SHEET
07	24/025	BA	AO	SH	30/01/2024	XBR-1TD0-014	SIZE 5 PRE-START VENTILATION SYSTEM	GENERAL ASSEMBLY	2:5	A3	2/3
06	DQN-12429	CE	RJ	AR	07/05/2020	RELEASED	SEE PART DETAILS	(MATERIAL)	20.6		
05	5889		MN	MP			SEE PART DETAILS	(FINISH)	ML645 - PV Systems		
							COMPLIANCE REQUIRED: REACH, RoHS & 3TG	(SCHEDULE DOC. REF)			



Expo Technologies Ltd. owns the copyright on this document and all rights are reserved. This document should be treated as confidential. It must not be used for any purpose other than that for which it is supplied, and must not be copied in whole or in part, or any part thereof, without the prior written consent of Expo Technologies Ltd. A copy of this document made by any method must also contain a copy of this legend.

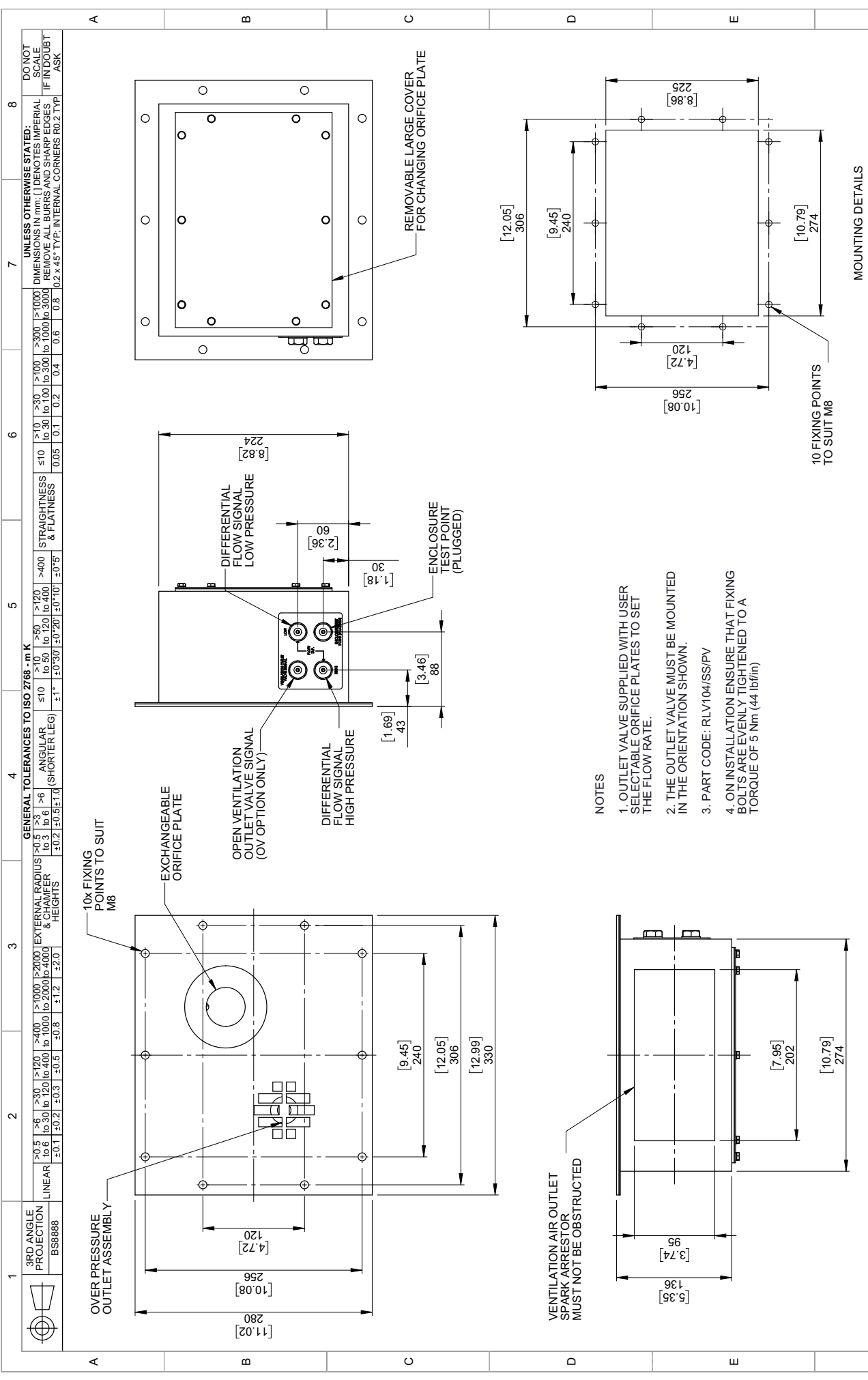

- NOTES**
1. OUTLET VALVE SUPPLIED WITH USER SELECTABLE ORIFICE PLATES TO SET THE FLOW RATE.
 2. THE OUTLET VALVE MUST BE MOUNTED IN THE ORIENTATION SHOWN.
 3. PART CODE: RLV104/SS/PV
 4. ON INSTALLATION ENSURE THAT FIXING BOLTS ARE EVENLY TIGHTENED TO A TORQUE OF 5 Nm (44 lbf/in)

MOUNTING DETAILS

REVISION		DRAWING No.		TITLE		DRAWING TYPE		SCALE		SHEET	
07	24/025	BA	AO	SH	30/01/2024	XBR-1TD0-014		5PV RLV		GENERAL ASSEMBLY	
06	DQN-12423	CE	RJ	AR	07/05/2020	RELEASED		STAINLESS STEEL - GRADE 316L		1:5 A3 3/3	
05	5989	MP	MN	MP	07/05/2020	07		VAPOUR BLASTED		Expo Technologies Ltd. owns the copyright on this document and all rights are reserved. This document should be treated as confidential; it must not be used for any purpose other than that for which it is supplied, and must not be copied in whole or in part, or any part thereof, without the prior written consent of Expo Technologies Ltd. A copy of this document made by any method must also contain a copy of this legend.	
						LIFE/CYCLE STATE		MATERIAL		FINISH	
						RELEASED		COMPLIANCE REQUIRED: REACH, RoHS & 3TG		ML645 - PV Systems	
						07		SCHEMATIC DOC. REF		7.0	
						07		SCHEDULE DOC. REF		ML645 - PV Systems	
						07		REVISION		7.0	
						07		FINISH		VAPOUR BLASTED	
						07		MATERIAL		STAINLESS STEEL - GRADE 316L	
						07		(MASS (kg))		7.0	
						07		COMPLIANCE REQUIRED: REACH, RoHS & 3TG		ML645 - PV Systems	



Expo Technologies Ltd. owns the copyright on this document and all rights are reserved. This document should be treated as confidential; it must not be used for any purpose other than that for which it is supplied, and must not be copied in whole or in part, or any part thereof, without the prior written consent of Expo Technologies Ltd. A copy of this document made by any method must also contain a copy of this legend.

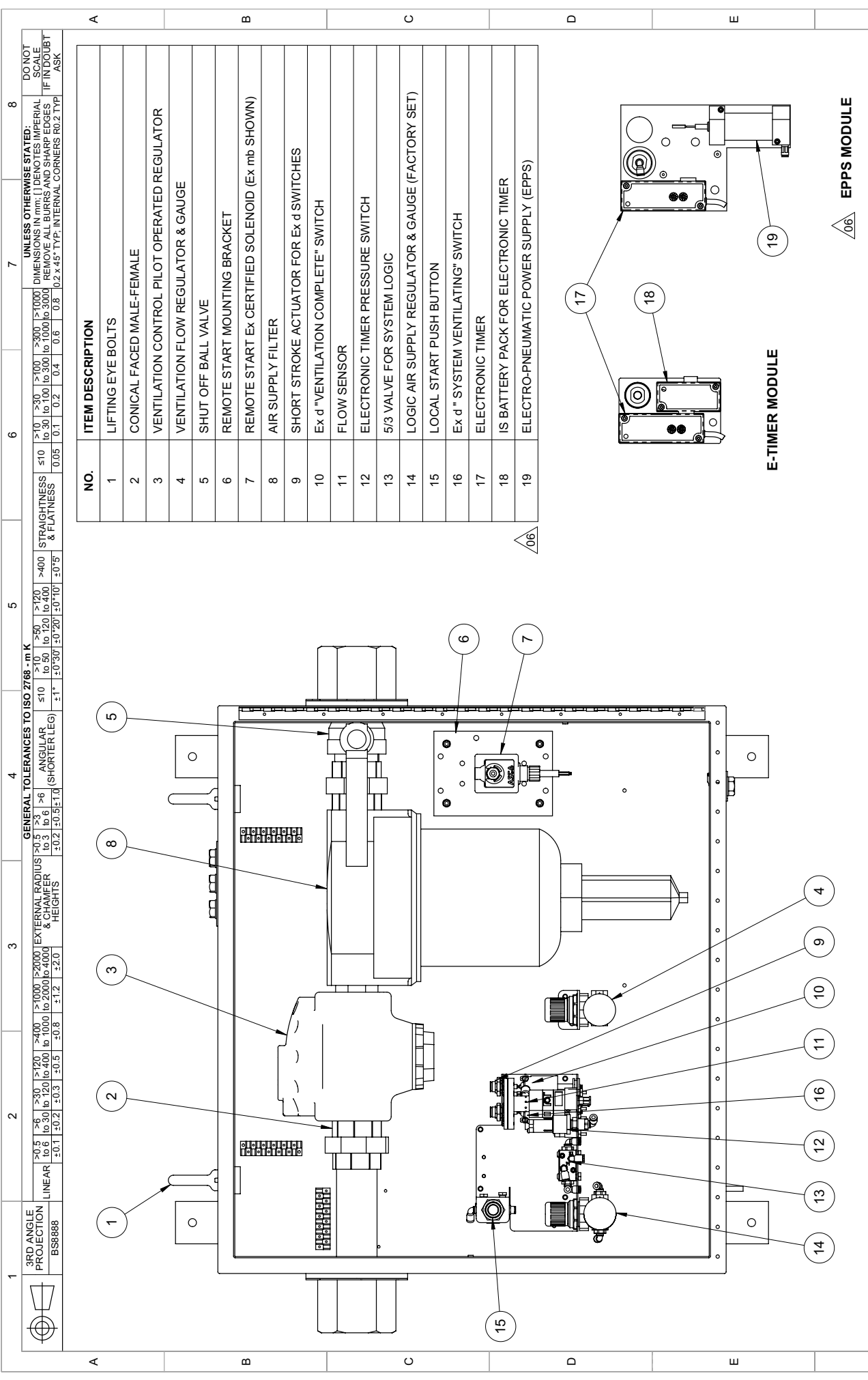

NO.	ITEM DESCRIPTION
1	LIFTING EYE BOLTS
2	CONICAL FACED MALE-FEMALE
3	VENTILATION CONTROL PILOT OPERATED REGULATOR
4	VENTILATION FLOW REGULATOR & GAUGE
5	SHUT OFF BALL VALVE
6	REMOTE START MOUNTING BRACKET
7	REMOTE START Ex CERTIFIED SOLENOID (Ex mb SHOWN)
8	AIR SUPPLY FILTER
9	SHORT STROKE ACTUATOR FOR Ex d SWITCHES
10	Ex d "VENTILATION COMPLETE" SWITCH
11	FLOW SENSOR
12	ELECTRONIC TIMER PRESSURE SWITCH
13	5/3 VALVE FOR SYSTEM LOGIC
14	LOGIC AIR SUPPLY REGULATOR & GAUGE (FACTORY SET)
15	LOCAL START PUSH BUTTON
16	Ex d " SYSTEM VENTILATING" SWITCH
17	ELECTRONIC TIMER
18	IS BATTERY PACK FOR ELECTRONIC TIMER
19	ELECTRO-PNEUMATIC POWER SUPPLY (EPPS)

06

06 EPPS MODULE

E-TIMER MODULE

1	3RD ANGLE PROJECTION BS8888	2	GENERAL TOLERANCES TO ISO 2768 - m K	3	EXTERNAL RADIUS	4	ANGULAR (SHORTER LEG)	5	STRAIGHTNESS & FLATNESS	6	DO NOT SCALE IF IN DOUBT ASK
	LINEAR		±0.5 to 0.1		±0.5 to 0.1		±1°		±0.05		SCALE
			±0.5 to 0.1		±0.5 to 0.1		±1°		±0.05		SIZE
			±0.5 to 0.1		±0.5 to 0.1		±1°		±0.05		SHEET
			±0.5 to 0.1		±0.5 to 0.1		±1°		±0.05		2/3

REVISION		DRAWING No.		TITLE		DRAWING TYPE		SCALE		SHEET	
06	24/025	BA	AO	SH	30/01/2024	XBR-1TD0-016		SIZE		2/3	
05	DQN-12436	CE	RJ	AR	18/05/2020	SIZE 7 PRE-START VENTILATION SYSTEM		GENERAL ASSEMBLY		A3	
04	5989	CB	CB	CB		RELEASED		06		06 EPPS MODULE	
		LIFE/CYCLE STATE		REVISION		MATERIAL		FINISH		COMPLIANCE REQUIRED: REACH, RoHS & 3TG	
		RELEASED		06		SEE PART DETAILS		SEE PART DETAILS		ML645 - PV Systems	
						SEE PART DETAILS		SEE PART DETAILS		43.0	
						COMPLIANCE REQUIRED: REACH, RoHS & 3TG		SCHEDULE DOC. REF		ML645 - PV Systems	
										43.0	
										ML645 - PV Systems	
										43.0	
										ML645 - PV Systems	
										43.0	
										ML645 - PV Systems	
										43.0	
										ML645 - PV Systems	
										43.0	
										ML645 - PV Systems	
										43.0	
										ML645 - PV Systems	
										43.0	
										ML645 - PV Systems	
										43.0	
										ML645 - PV Systems	
										43.0	
										ML645 - PV Systems	
										43.0	
										ML645 - PV Systems	
										43.0	
										ML645 - PV Systems	
										43.0	
										ML645 - PV Systems	
										43.0	
										ML645 - PV Systems	
										43.0	
										ML645 - PV Systems	
										43.0	
										ML645 - PV Systems	
										43.0	
										ML645 - PV Systems	
										43.0	
										ML645 - PV Systems	
										43.0	
										ML645 - PV Systems	
										43.0	
										ML645 - PV Systems	
										43.0	
										ML645 - PV Systems	
										43.0	
										ML645 - PV Systems	
										43.0	
										ML645 - PV Systems	
										43.0	
										ML645 - PV Systems	
										43.0	
										ML645 - PV Systems	
										43.0	
										ML645 - PV Systems	
										43.0	
										ML645 - PV Systems	
										43.0	
										ML645 - PV Systems	
										43.0	
										ML645 - PV Systems	
										43.0	
										ML645 - PV Systems	
										43.0	
										ML645 - PV Systems	
										43.0	
										ML645 - PV Systems	
										43.0	
										ML645 - PV Systems	
										43.0	
										ML645 - PV Systems	
										43.0	
										ML645 - PV Systems	
										43.0	
										ML645 - PV Systems	
										43.0	
										ML645 - PV Systems	
										43.0	
										ML645 - PV Systems	
										43.0	
										ML645 - PV Systems	
										43.0	
										ML645 - PV Systems	
										43.0	
										ML645 - PV Systems	
										43.0	
										ML645 - PV Systems	
										43.0	
										ML645 - PV Systems	
										43.0	
										ML645 - PV Systems	
										43.0	
										ML645 - PV Systems	
										43.0	
										ML645 - PV Systems	
										43.0	
										ML645 - PV Systems	
										43.0	
										ML645 - PV Systems	
										43.0	
										ML645 - PV Systems	
										43.0	
										ML645 - PV Systems	
										43.0	
										ML645 - PV Systems	
										43.0	
										ML645 - PV Systems	
										43.0	
										ML645 - PV Systems	
										43.0	
										ML645 - PV Systems	
										43.0	
										ML645 - PV Systems	
										43.0	
										ML645 - PV Systems	
										43.0	
										ML645 - PV Systems	
										43.0	
										ML645 - PV Systems	
										43.0	
										ML645 - PV Systems	
										43.0	
										ML645 - PV Systems	
										43.0	
										ML645 - PV Systems	
										43.0	
										ML645 - PV Systems	
										43.0	
										ML645 - PV Systems	
										43.0	
										ML645 - PV Systems	
										43.0	
										ML645 - PV Systems	
										43.0	
										ML645 - PV Systems	
										43.0	
										ML645 - PV Systems	
										43.0	
										ML645 - PV Systems	
										43.0	
										ML645 - PV Systems	
										43.0	
										ML645 - PV Systems	
										43.0	
										ML645 - PV Systems	
										43.0	
										ML645 - PV Systems	
										43.0	
										ML645 - PV Systems	
										43.0	
										ML645 - PV Systems	
										43.0	
										ML645 - PV Systems	
										43.0	
										ML645 - PV Systems	
										43.0	
										ML645 - PV Systems	
										43.0	
										ML645 - PV Systems	
										43.0	
										ML645 - PV Systems	
										43.0	
										ML645 - PV Systems	
										43.0	
										ML645 - PV Systems	
										43.0	
										ML645 - PV Systems	
										43.0	
										ML645 - PV Systems	
										43.0	
										ML645 - PV Systems	
								</			

8	7	6	5	4	3	2	1
3RD ANGLE PROJECTION 	DIMENSIONS IN mm [] DENOTES IMPERIAL	DO NOT SCALE	IF IN DOUBT ASK	The contents of this drawing / document are Copyright © Expo Technologies Limited. They are to be treated as confidential and are returnable upon request. They are not to be copied or communicated in part or in whole without written consent from Expo Technologies Limited, neither are they to be used in any way against our interests.			

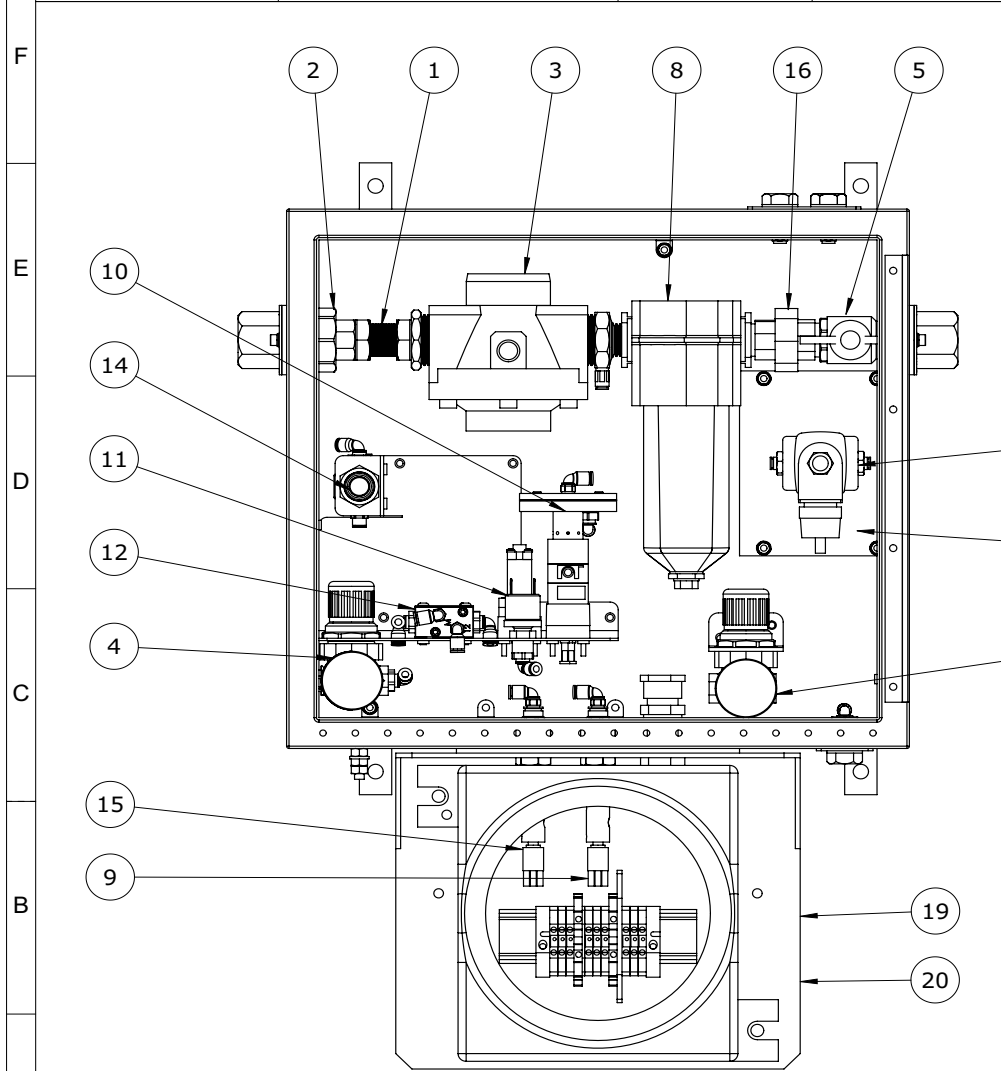

NO.	DESCRIPTION
1	ADJUSTABLE LENGTH THREADED PIPE
2	CONICAL FACED FEMALE-FEMALE UNION (CONTAINING REMOVABLE RESTRICTOR)
3	VENTILATION CONTROL PILOT OPERATED REGULATOR
4	LOGIC AIR SUPPLY REGULATOR & GAUGE (FACTORY SET)
5	SHUT OFF BALL VALVE
6	REMOTE START MOUNTING BRACKET
7	REMOTE START Ex CERTIFIED SOLENOID (Ex d SHOWN)
8	AIR SUPPLY FILTER
9	"VENTILATION COMPLETE" SWITCH ACTUATOR
10	FLOW SENSOR
11	ELECTRONIC TIMER PRESSURE SWITCH
12	5/3 VALVE FOR SYSTEM LOGIC
13	VENTILATION FLOW REGULATOR & GAUGE
14	LOCAL START PUSHBUTTON
15	"SYSTEM VENTILATING" SWITCH ACTUATOR
16	CONICAL FACED MALE-FEMALE UNION
17	IS BATTERY PACK FOR ELECTRONIC TIMER
18	ELECTRONIC TIMING MODULE
19	MIU dT BOX CLASS I, DIV I, GRP B, C&D-SEE AMU-BAA1-624
20	MIU MOUNTING BRACKET

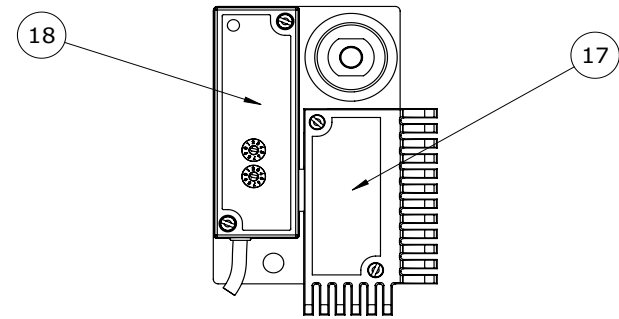

BREAK OUT SECTION OF E-TIMER MODULE

A	DRAWN DATE: 07/11/2018		TOLERANCES UNLESS OTHERWISE STATED		MATERIAL SEE DRAWING		FIRST USED ON 53877		SCALE 1:5		REV. D	
	DRAWING STATUS: BUILD		DECIMALS STD ±1°		FINISH SEE DRAWING		WEIGHT		DRAWING No.		3PV-SS-RS41-N-ET-PO-US	
	APPROVED	CHECKED	DRAWN	X ±0.5								
	PB	RD	LG	X-X ±0.2								
			X-XX ±0.1									
			FLATNESS TO BE LESS THAN 0.4 OVER ANY 100mm LENGTH									
Expo Technologies Limited SURREY TW16 5DB UNITED KINGDOM											SHEET No. 2 OF 3	
TITLE SIZE 3 PRE-START VENTILATION SYSTEM											ex+po	

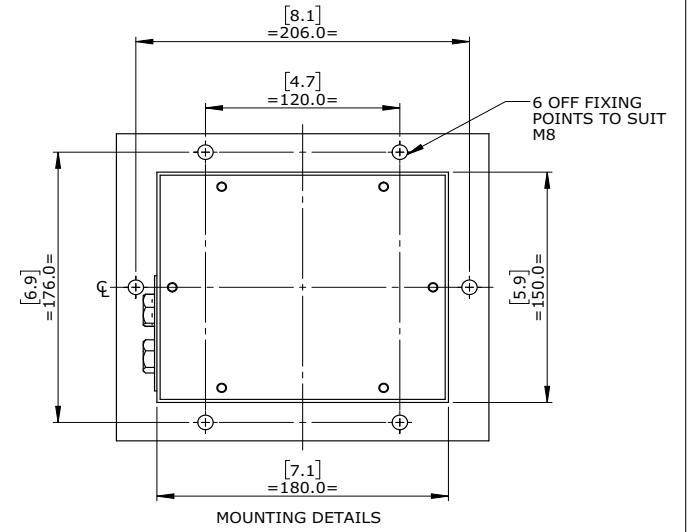
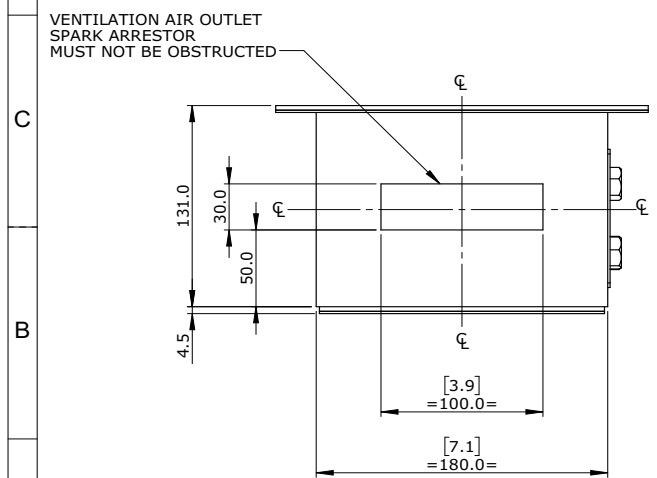
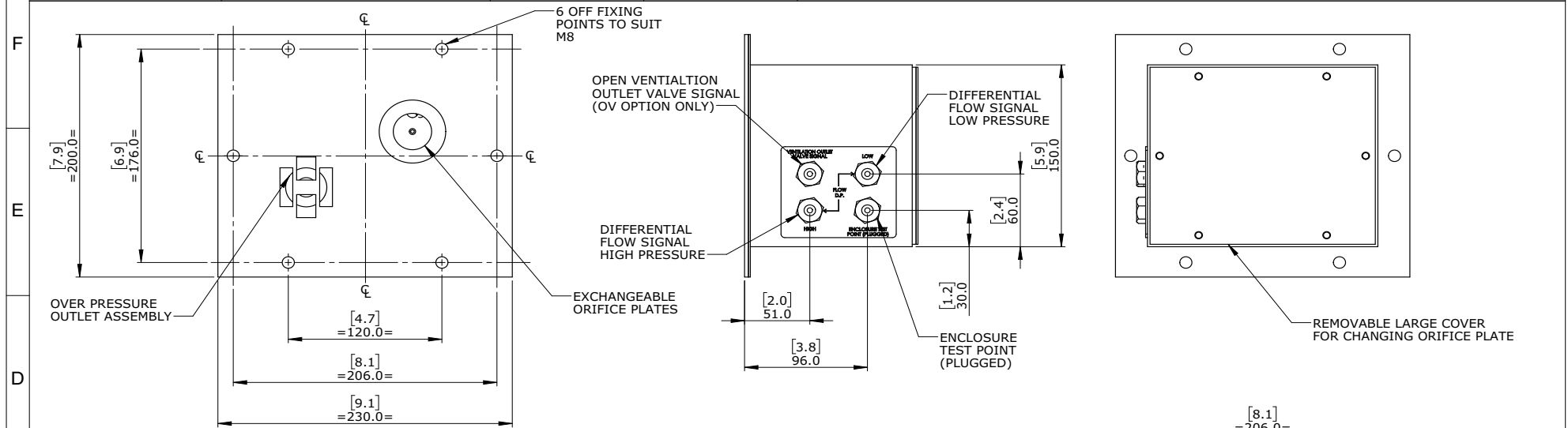

- NOTES**
1. OUTLET VALVE SUPPLIED WITH USER SELECTABLE ORIFICE PLATES TO SET THE FLOW RATE
 2. THE OUTLET VALVE MUST BE MOUNTED IN ORIENTATION SHOWN.
 3. WEIGHT IS APPROXIMATELY 4KG
 4. PART CODE RLV052/SS/PV
 5. ON INSTALLATION ENSURE THAT FIXING BOLTS ARE EVENLY TIGHTENED TO A TORQUE OF 5Nm (44 lbf/in)

A	DRAWN DATE: 07/11/2018	TOLERANCES UNLESS OTHERWISE STATED DECIMALS ANGLE X ±0.5 STD ±1° X.X ±0.2 X.XX ±0.1	MATERIAL	Expo Technologies Limited SURREY TW16 5DB UNITED KINGDOM	FIRST USED ON 53877	SCALE A3 1:5	REV. D
	DRAWING STATUS: BUILD			FINISH	WEIGHT	DRAWING No. 3PV-SS-RS41-N-ET-PO-US	
	APPROVED	CHECKED	DRAWN			SHEET No. 3 of 3	
	PB	RD	LG	TITLE RLV52 OUTLET VALVE			



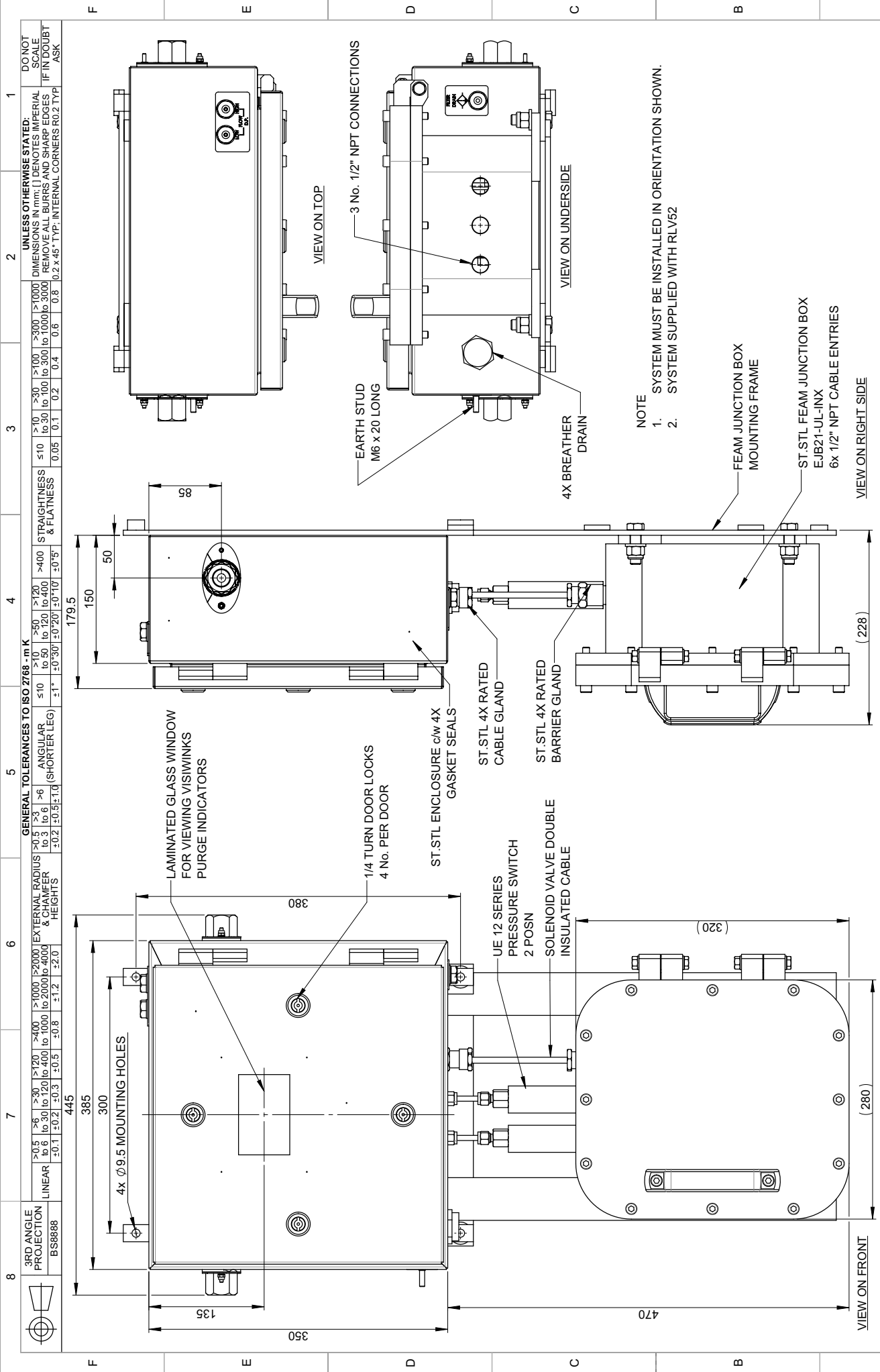

NOTE
 1. SYSTEM MUST BE INSTALLED IN ORIENTATION SHOWN.
 2. SYSTEM SUPPLIED WITH RLV52

3RD ANGLE PROJECTION BS8888	GENERAL TOLERANCES TO ISO 2768 - m K	
	LINEAR	ANGULAR
>0.5 to 6 ±0.1 to ±0.2	>30 to 120 ±0.3 to ±0.5	>10 to 30 ±0.1 to ±0.2
>6 to 30 ±0.2 to ±0.3	>120 to 400 ±0.5 to ±0.8	>30 to 100 ±0.4 to ±0.6
>30 to 400 ±0.8 to ±1.2	>400 to 2000 ±1.2 to ±2.0	>100 to 300 ±0.6 to ±0.8
>400 to 2000 ±1.2 to ±2.0	>2000 to 4000 ±1.2 to ±2.0	>300 to 1000 ±0.8 to ±1.0
>4000 to 20000 ±1.2 to ±2.0	>20000 to 40000 ±1.2 to ±2.0	>1000 to 3000 ±1.0 to ±1.5
>20000 to 40000 ±1.2 to ±2.0	>40000 to 200000 ±1.2 to ±2.0	>3000 to 10000 ±1.0 to ±1.5
>40000 to 200000 ±1.2 to ±2.0	>200000 to 400000 ±1.2 to ±2.0	>10000 to 30000 ±1.0 to ±1.5
>200000 to 400000 ±1.2 to ±2.0	>400000 to 2000000 ±1.2 to ±2.0	>30000 to 100000 ±1.0 to ±1.5
>400000 to 2000000 ±1.2 to ±2.0	>2000000 to 4000000 ±1.2 to ±2.0	>100000 to 300000 ±1.0 to ±1.5
>2000000 to 4000000 ±1.2 to ±2.0	>4000000 to 20000000 ±1.2 to ±2.0	>300000 to 1000000 ±1.0 to ±1.5
>4000000 to 20000000 ±1.2 to ±2.0	>20000000 to 40000000 ±1.2 to ±2.0	>1000000 to 3000000 ±1.0 to ±1.5
>20000000 to 40000000 ±1.2 to ±2.0	>40000000 to 200000000 ±1.2 to ±2.0	>3000000 to 10000000 ±1.0 to ±1.5
>40000000 to 200000000 ±1.2 to ±2.0	>200000000 to 400000000 ±1.2 to ±2.0	>10000000 to 30000000 ±1.0 to ±1.5
>200000000 to 400000000 ±1.2 to ±2.0	>400000000 to 2000000000 ±1.2 to ±2.0	>30000000 to 100000000 ±1.0 to ±1.5
>400000000 to 2000000000 ±1.2 to ±2.0	>2000000000 to 4000000000 ±1.2 to ±2.0	>100000000 to 300000000 ±1.0 to ±1.5
>2000000000 to 4000000000 ±1.2 to ±2.0	>4000000000 to 20000000000 ±1.2 to ±2.0	>300000000 to 1000000000 ±1.0 to ±1.5
>4000000000 to 20000000000 ±1.2 to ±2.0	>20000000000 to 40000000000 ±1.2 to ±2.0	>1000000000 to 3000000000 ±1.0 to ±1.5
>20000000000 to 40000000000 ±1.2 to ±2.0	>40000000000 to 200000000000 ±1.2 to ±2.0	>3000000000 to 10000000000 ±1.0 to ±1.5
>40000000000 to 200000000000 ±1.2 to ±2.0	>200000000000 to 400000000000 ±1.2 to ±2.0	>10000000000 to 30000000000 ±1.0 to ±1.5
>200000000000 to 400000000000 ±1.2 to ±2.0	>400000000000 to 2000000000000 ±1.2 to ±2.0	>30000000000 to 100000000000 ±1.0 to ±1.5
>400000000000 to 2000000000000 ±1.2 to ±2.0	>2000000000000 to 4000000000000 ±1.2 to ±2.0	>100000000000 to 300000000000 ±1.0 to ±1.5
>2000000000000 to 4000000000000 ±1.2 to ±2.0	>4000000000000 to 20000000000000 ±1.2 to ±2.0	>300000000000 to 1000000000000 ±1.0 to ±1.5
>4000000000000 to 20000000000000 ±1.2 to ±2.0	>20000000000000 to 40000000000000 ±1.2 to ±2.0	>1000000000000 to 3000000000000 ±1.0 to ±1.5
>20000000000000 to 40000000000000 ±1.2 to ±2.0	>40000000000000 to 200000000000000 ±1.2 to ±2.0	>3000000000000 to 10000000000000 ±1.0 to ±1.5
>40000000000000 to 200000000000000 ±1.2 to ±2.0	>200000000000000 to 400000000000000 ±1.2 to ±2.0	>10000000000000 to 30000000000000 ±1.0 to ±1.5
>200000000000000 to 400000000000000 ±1.2 to ±2.0	>400000000000000 to 2000000000000000 ±1.2 to ±2.0	>30000000000000 to 100000000000000 ±1.0 to ±1.5
>400000000000000 to 2000000000000000 ±1.2 to ±2.0	>2000000000000000 to 4000000000000000 ±1.2 to ±2.0	>100000000000000 to 300000000000000 ±1.0 to ±1.5
>2000000000000000 to 4000000000000000 ±1.2 to ±2.0	>4000000000000000 to 20000000000000000 ±1.2 to ±2.0	>300000000000000 to 1000000000000000 ±1.0 to ±1.5
>4000000000000000 to 20000000000000000 ±1.2 to ±2.0	>20000000000000000 to 40000000000000000 ±1.2 to ±2.0	>1000000000000000 to 3000000000000000 ±1.0 to ±1.5

REVISION	ECR No.	DRAWN	CHECKED	APPROVED	DATE	DRAWING No.	TITLE	DRAWING TYPE	SCALE	SIZE	SHEET
01	231/06	PB	SH	TH	12/07/2023		4X 3PV/SS/RS24/NET/PO/US	GENERAL ASSEMBLY	1:4	A3	1/2
A	-	PB	SH	TH	17/04/2023		SEE PART DETAILS				
		LIFECYCLE STATE		REVISION		MATERIAL		FINISH		COMPLIANCE REQUIRED, REACH, RoHS & 3TG	
		RELEASED		01		STAINLESS STEEL - GRADE 316L		58.75		ML645 - PV Systems	
						SCHEDULE DOC. REF					



Expo Technologies Ltd. owns the copyright on this document and all rights are reserved. This document should be treated as confidential. It must not be used for any purpose disclosed to 3rd parties, without the prior written consent of Expo Technologies Ltd. Any copy of this document made by any method must also contain a copy of this legend.

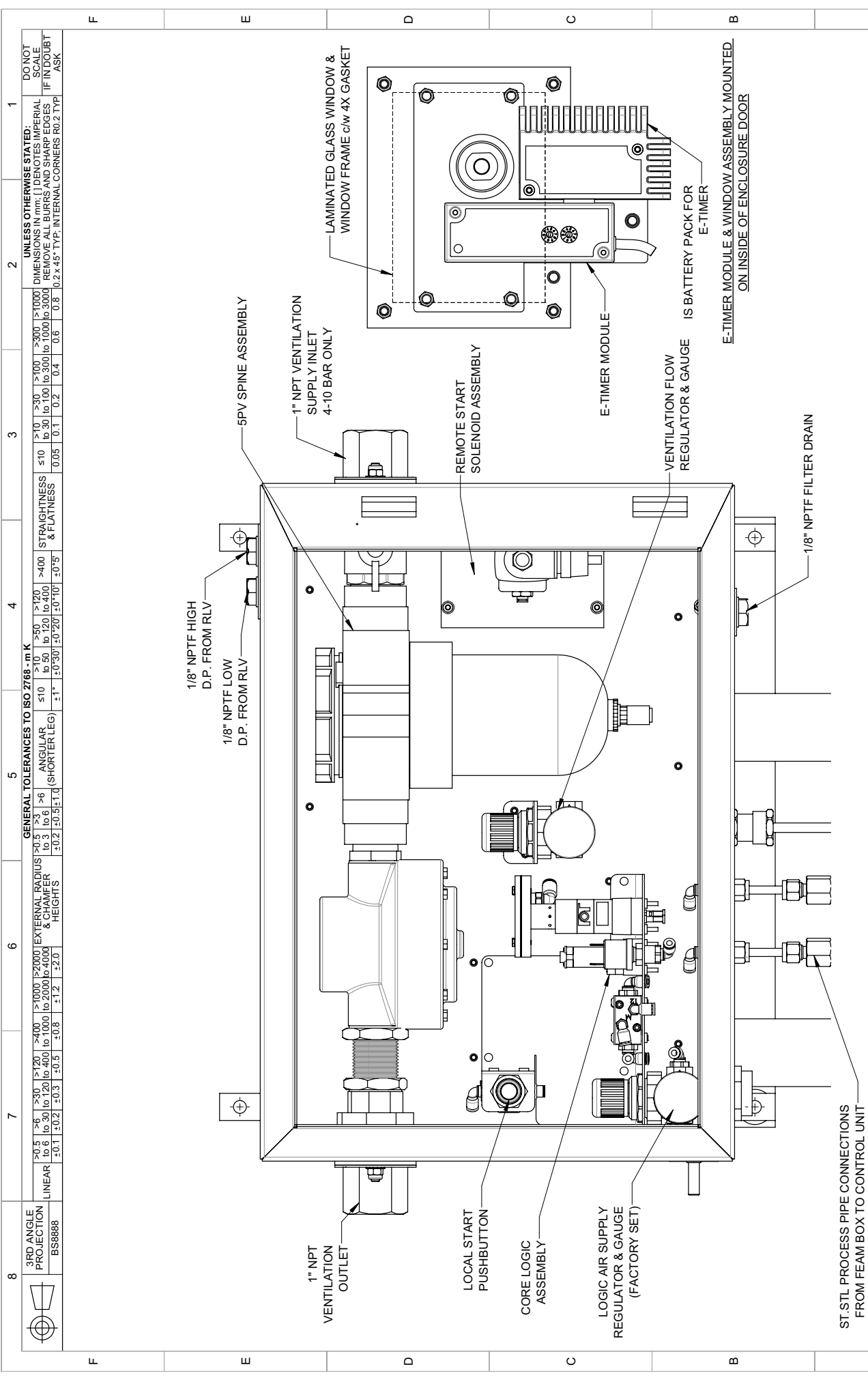

8	3RD ANGLE PROJECTION BS8888	7	6	5	4	3	2	1	
LINEAR >0.5 to 0.5 ±0.1 >30 to 0.3 ±0.2 >120 to 0.3 ±0.3 >400 to 0.5 ±0.5 >1000 to 1.0 ±1.0 >2000 to 2.0 ±2.0 >4000 to 4.0 ±4.0		GENERAL TOLERANCES TO ISO 2768 - m K >0.5 to 0.3 ±0.2 >3 to 0.3 ±0.3 >6 to 0.3 ±0.3 >10 to 0.3 ±0.3 >15 to 0.3 ±0.3 >20 to 0.3 ±0.3 >30 to 0.3 ±0.3 >40 to 0.3 ±0.3 >50 to 0.3 ±0.3 >60 to 0.3 ±0.3 >70 to 0.3 ±0.3 >80 to 0.3 ±0.3 >90 to 0.3 ±0.3 >100 to 0.3 ±0.3 >120 to 0.3 ±0.3 >150 to 0.3 ±0.3 >200 to 0.3 ±0.3 >300 to 0.3 ±0.3 >400 to 0.3 ±0.3 >500 to 0.3 ±0.3 >600 to 0.3 ±0.3 >700 to 0.3 ±0.3 >800 to 0.3 ±0.3 >900 to 0.3 ±0.3 >1000 to 0.3 ±0.3 >1200 to 0.3 ±0.3 >1500 to 0.3 ±0.3 >2000 to 0.3 ±0.3 >3000 to 0.3 ±0.3 >4000 to 0.3 ±0.3 >5000 to 0.3 ±0.3 >6000 to 0.3 ±0.3 >7000 to 0.3 ±0.3 >8000 to 0.3 ±0.3 >9000 to 0.3 ±0.3 >10000 to 0.3 ±0.3		STRAIGHTNESS & FLATNESS ≤ 0.05 ≤ 0.1 ≤ 0.2 ≤ 0.4 ≤ 0.6 ≤ 1.0 ≤ 1.5 ≤ 2.0 ≤ 3.0 ≤ 4.0 ≤ 5.0 ≤ 6.0 ≤ 7.0 ≤ 8.0 ≤ 9.0 ≤ 10.0 ≤ 12.0 ≤ 15.0 ≤ 20.0 ≤ 30.0 ≤ 40.0 ≤ 50.0 ≤ 60.0 ≤ 70.0 ≤ 80.0 ≤ 90.0 ≤ 100.0 ≤ 120.0 ≤ 150.0 ≤ 200.0 ≤ 300.0 ≤ 400.0 ≤ 500.0 ≤ 600.0 ≤ 700.0 ≤ 800.0 ≤ 900.0 ≤ 1000.0		DIMENSIONS IN mm: [] DENOTES IMPERIAL REMOVE ALL BURRS AND SHARP EDGES IF IN DOUBT ASK		DO NOT SCALE IF IN DOUBT ASK	

DRAWING No.		DATE		APPROVED		CHECKED		DRAWN		REVISION		TITLE		DRAWING TYPE		SCALE		SIZE		SHEET	
4X 5PV SYSTEM		12/07/2023		TH		SH		PB		01		4X 5PV/SS/RS24/NIET/PO/US		GENERAL ASSEMBLY		1:2.5		A3		2/2	
RELEASED		17/04/2023		TH		SH		PB		01		SEE PART DETAILS		ML645 - PV Systems						expo technologies	
LIFECYCLE STATE		REVISION		MATERIAL		FINISH		COMPLIANCE REQUIRED		(MASS (kg))		SCHEDULE DOC. REF.		THIS DOCUMENT IS THE PROPERTY OF expo technologies Ltd. save the copyright on this document and all rights are reserved. This document should be treated as confidential. It must not be used for any purpose other than that for which it is supplied, and must not be copied in whole or in part, or copy of this document made by any method must also contain a copy of this legend.							
RELEASED		01		STAINLESS STEEL - GRADE 316L		SEE PART DETAILS		REACH, RoHS & 3TG		57.83		ML645 - PV Systems									
8		7		6		5		4		3		2		1							

ST-STL PROCESS PIPE CONNECTIONS FROM FEAM BOX TO CONTROL UNIT

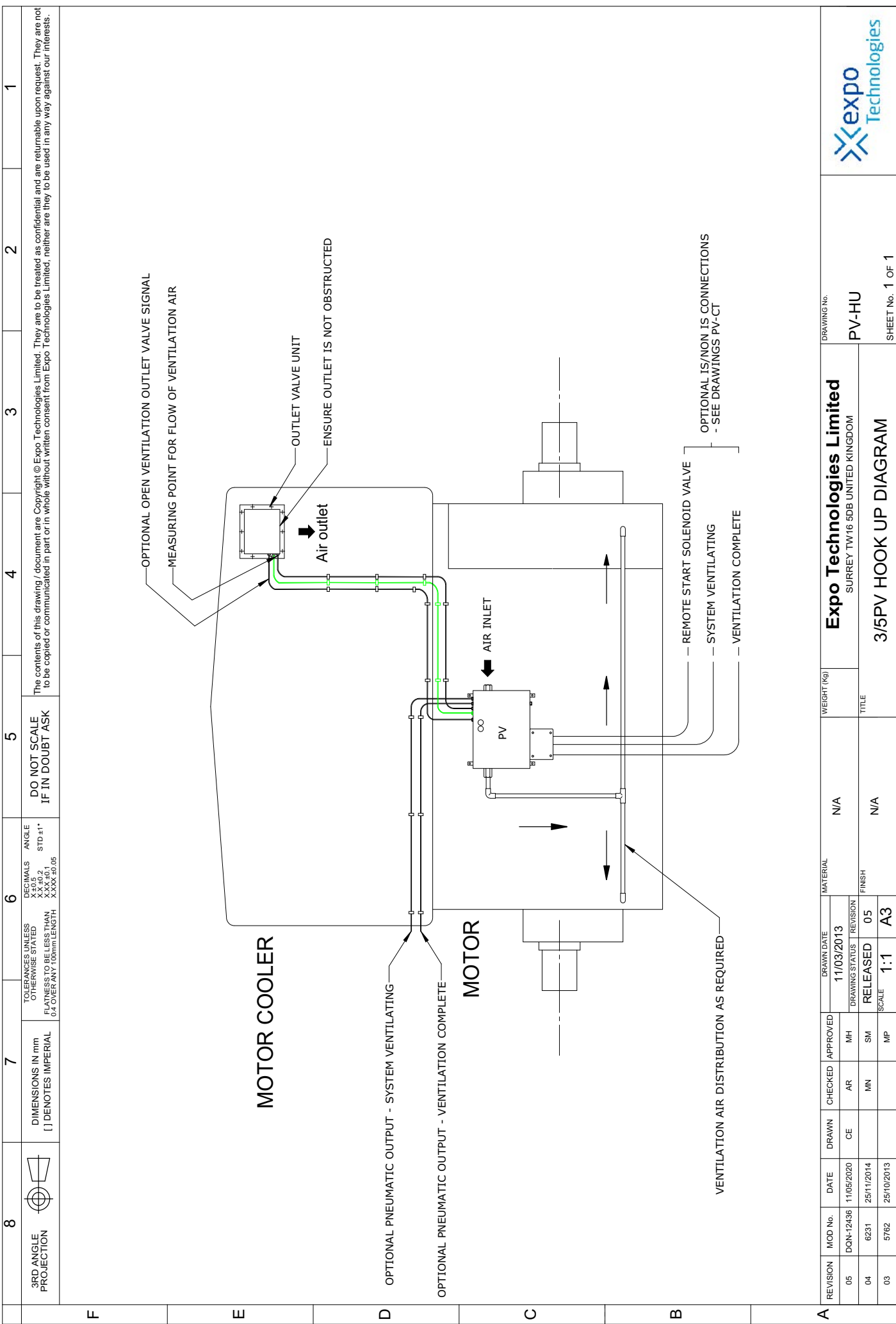

8	3RD ANGLE PROJECTION	7	DIMENSIONS IN mm () DENOTES IMPERIAL	6	TO TOLERANCES UNLESS OTHERWISE STATED FLATNESS TO BE LESS THAN 0.4 OVER ANY 100mm LENGTH	5	DO NOT SCALE IF IN DOUBT ASK	4	3	2	1
---	----------------------	---	--	---	---	---	------------------------------	---	---	---	---

The contents of this drawing / document are Copyright © Expo Technologies Limited. They are to be treated as confidential and are returnable upon request. They are not to be copied or communicated in part or in whole without written consent from Expo Technologies Limited, neither are they to be used in any way against our interests.

A	REVISION	MOD No.	DATE	DRAWN	CHECKED	APPROVED	DRAWN DATE	MATERIAL	WEIGHT (kg)	Expo Technologies Limited SURREY TW16 5DB UNITED KINGDOM		DRAWING No.
	05	DGN-12436	11/05/2020	CE	AR	MH	11/03/2013		N/A			PV-HU
	04	6231	25/11/2014		WN	SM	RELEASED	05	N/A	3/5PV HOOK UP DIAGRAM		SHEET No. 1 OF 1
03	5762	25/10/2013			MP	SCALE	1:1	A3				



3rd ANGLE
PROJECTION

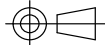

DIMENSIONS IN mm
DO NOT SCALE

UNSPECIFIED TOLERANCES
NO DEC PLACE ±0.5
1 DEC PLACE ±0.2
2 DEC PLACE ±0.1
FLATNESS TO BE LESS THAN 0.4mm OVER ANY 100mm LENGTH

The contents of this drawing / document are Copyright © Expo Technologies Limited. They are to be treated as confidential and are returnable upon request. They are not to be copied or communicated in part or in whole without written consent from Expo Technologies Limited, neither are they to be used in any way against our interests.

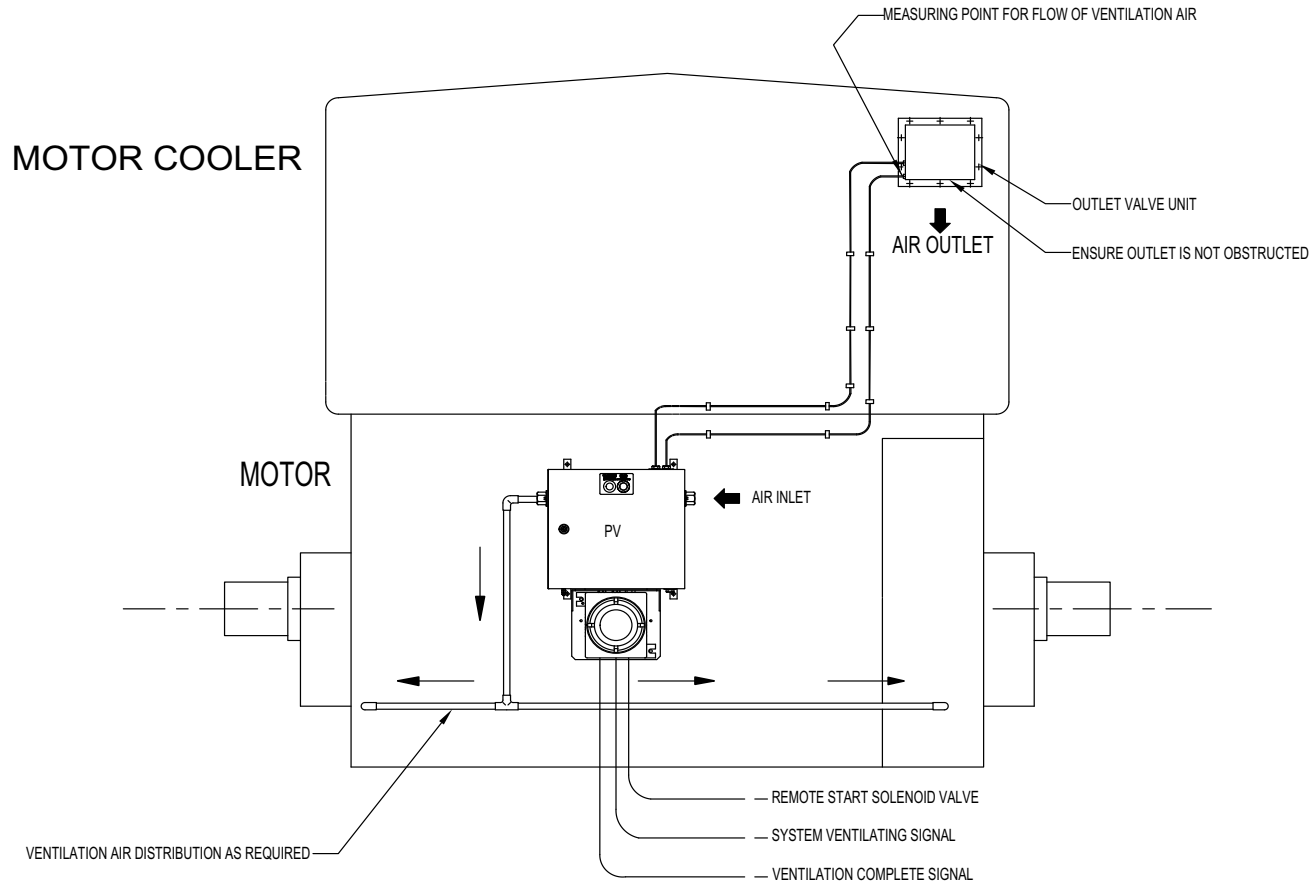

APP'D	JPdB	ISSUE:	1				MATERIAL	Expo Technologies Limited SURREY TW16 5DB UNITED KINGDOM		SCALE	-	
CHK'D	NH	MOD. No:	DRAWN				FINISH			TITLE	DRAWING No.	3PV-PO-HU
DR'WN	LG	DATE:	17/01/2019					JOB No:	CUSTOMER:	SHEET No.	1 OF 1	
		APPROVED:	JPdB									
		DRAWING STATUS: RELEASED										

3rd ANGLE PROJECTION 

DIMENSIONS IN mm
DO NOT SCALE

UNSPECIFIED NO DEC PLACE ±0.5
TOLERANCES 1 DEC PLACE ±0.2
2 DEC PLACE ±0.1
FLATNESS TO BE LESS THAN 0.4mm OVER ANY 100mm LENGTH

The contents of this drawing / document are Copyright © Expo Technologies Limited. They are to be treated as confidential and are returnable upon request. They are not to be copied or communicated in part or in whole without written consent from Expo Technologies Limited, neither are they to be used in any way against our interests.

MIN PIPING I.D.	
3PV	1/2" [12mm]

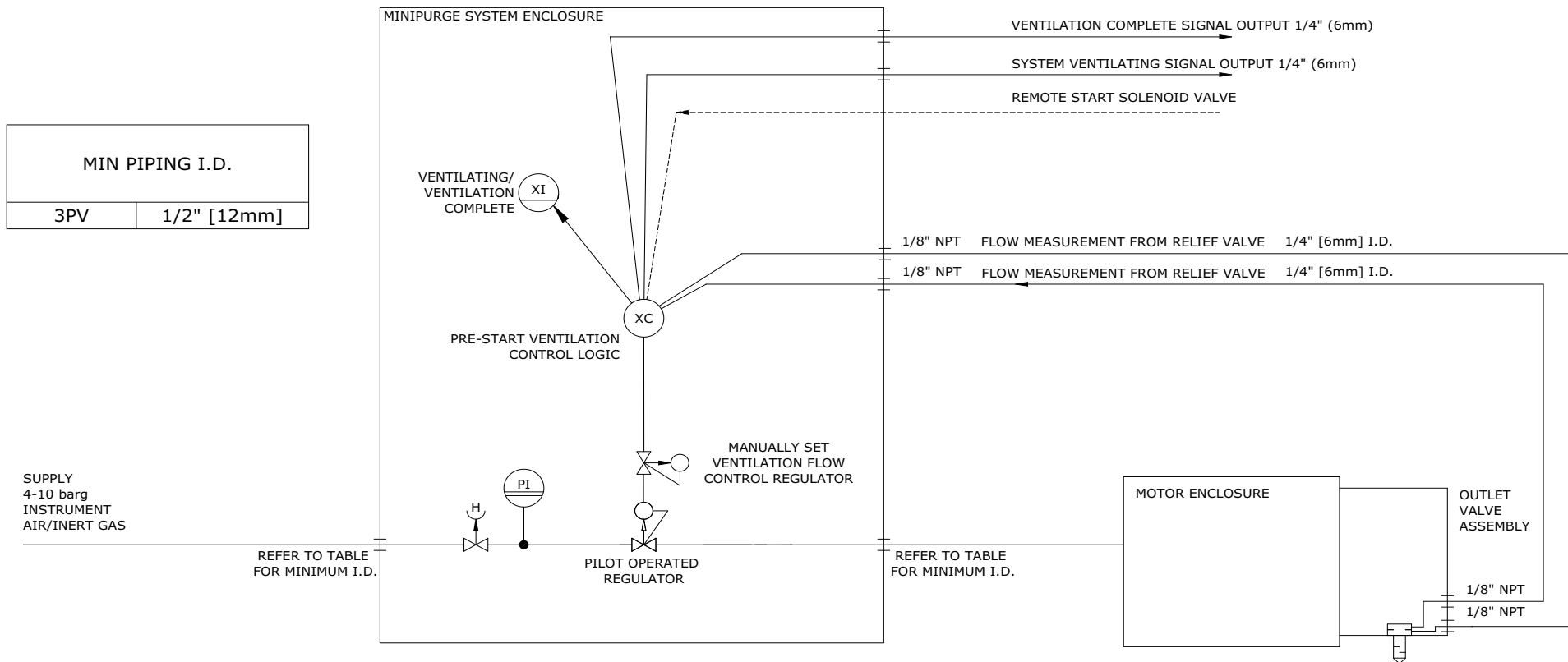

----- ELECTRICAL SIGNAL VIA Ex d EXPLOSION PROOF BOX
 _____ PNEUMATIC OUTPUTS

APP'D	JPdB	ISSUE:	01			
		MOD. No:	DRAWN			
CHK'D	NH	DATE:	17/01/2019			
		APPROVED:	JPdB			
DRWN	LG	DRAWING STATUS: RELEASED				

MATERIAL	N/A
FINISH	N/A

Expo Technologies Limited		SURREY TW16 5DB UNITED KINGDOM
TITLE PO PRESTART SYSTEM P & I DIAGRAM		
JOB No:	CUSTOMER:	

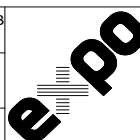

SCALE	NTS
DRAWING No.	3PV-PO-PI
SHEET No.	1 OF 1

8	3RD ANGLE PROJECTION	
7	DIMENSIONS IN mm [] DENOTES IMPERIAL	
6	TOLERANCES UNLESS OTHERWISE STATED FLATNESS TO BE LESS THAN 0.4 OVER ANY 100mm LENGTH	DECIMALS ANGLE X.XX ±0.2 STD ±1° X.XXX ±0.05
5	DO NOT SCALE IF IN DOUBT ASK	
4		
3		
2		
1		

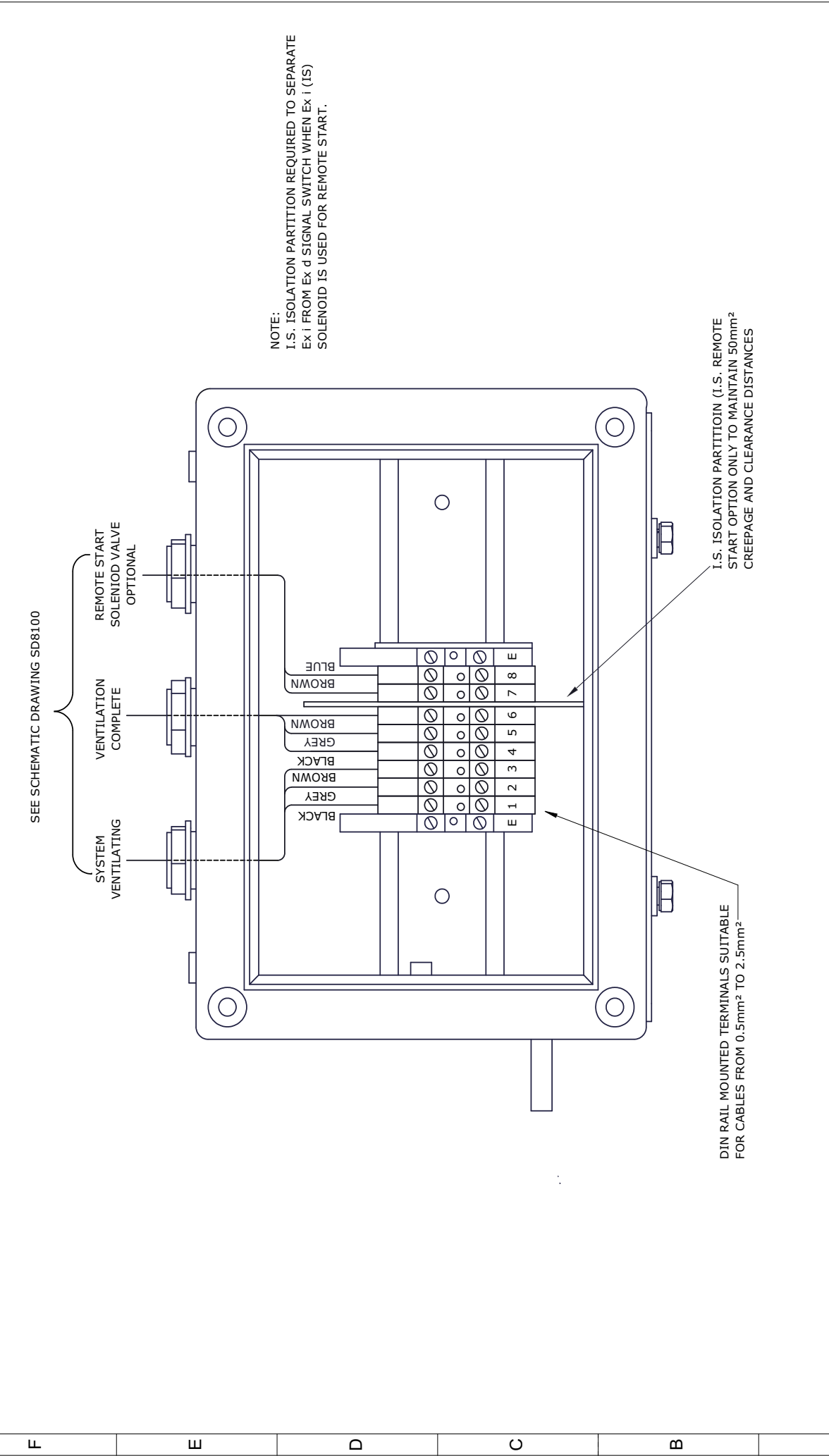

A		REVISION	MOD No.	DATE	DRAWN	CHECKED	APPROVED	DRAWN DATE	MATERIAL	WEIGHT (Kg)	Expo Technologies Limited SURREY TW16 5DB UNITED KINGDOM		DRAWING No. AGE-WC00-230
04		DON-124236		11/05/2020	CE	AR	MH	23/09/2013					
03		6249		12/01/2015		MIN	SJM	RELEASED	FINISH				
02		5954		18/10/2013			MP	SCALE 1:10	A3				
											EX E JUNCTION BOX LAYOUT		SHEET No. 1 OF 1
											Expo Technologies		

8	7	6	5	4	3	2	1
3RD ANGLE PROJECTION 	DIMENSIONS IN mm [] DENOTES IMPERIAL DO NOT SCALE	UNSPECIFIED TOLERANCES FLATNESS TO BE LESS THAN 0.4mm OVER ANY 100mm LENGTH	NO DEC PLACE ±0.5 1 DEC PLACE ±0.2 2 DEC PLACE ±0.1	The contents of this drawing / document are Copyright © Expo Technologies Limited. They are to be treated as confidential and are returnable upon request. They are not to be copied or communicated in part or in whole without written consent from Expo Technologies Limited, neither are they to be used in any way against our interests.			

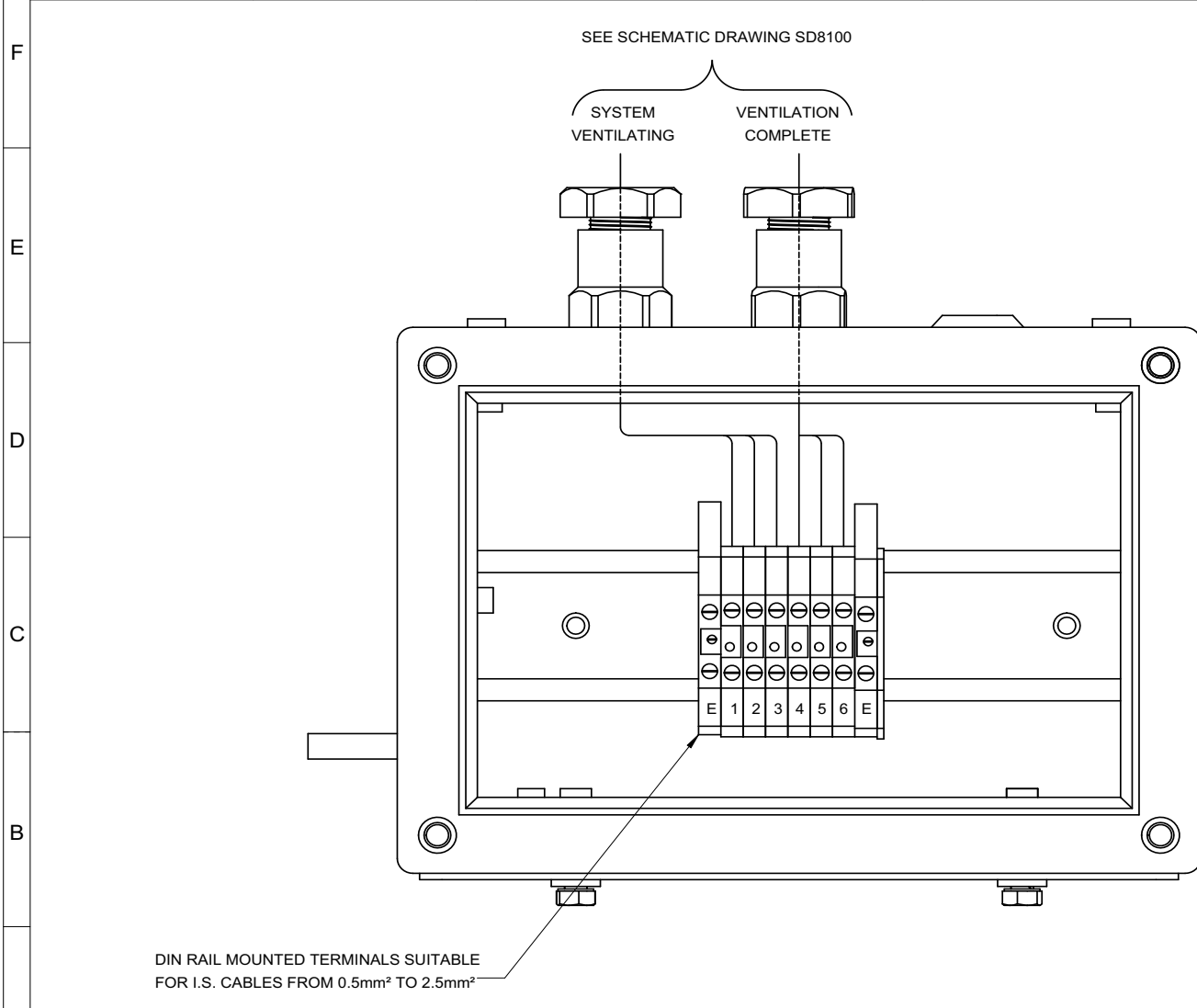

- NOTES:
- JUNCTION BOX NEMA 4X, IP66 RATED
 - FOR USE WITH INTRINSICALLY SAFE CIRCUITS ONLY

REVISION TABLE				DRAWN DATE: 23/01/2017	MATERIAL	Expo Technologies Limited SURREY TW16 5DB UNITED KINGDOM		IF IN DOUBT ASK	
REV.	MOD NUMBER	APPROVED DATE	APPROVED	DRAWING STATUS: PRODUCTION	TITLE: NEMA 4X, IP66 JUNCTION BOX - I.S. TERMINAL LAYOUT		A3	SCALE 1:1	REV. 01
01	DRAWN	24/01/2017	MLC	APPROVED CHECKED DRAWN MLC BG NW	FINISH	WEIGHT	JOB No. 51332	CUSTOMER	DRAWING No. AMU-D1S4-011
							SHEET No. 1 OF 1		

3rd ANGLE
PROJECTION



DIMENSIONS IN mm
DO NOT SCALE

UNSPECIFIED NO DEC PLACE ±0.5
TOLERANCES 1 DEC PLACE ±0.2
2 DEC PLACE ±0.1
FLATNESS TO BE LESS THAN 0.4mm OVER ANY 100mm LENGTH

The contents of this drawing / document are Copyright © Expo Technologies Limited. They are to be treated as confidential and are returnable upon request. They are not to be copied or communicated in part or in whole without written consent from Expo Technologies Limited, neither are they to be used in any way against our interests.

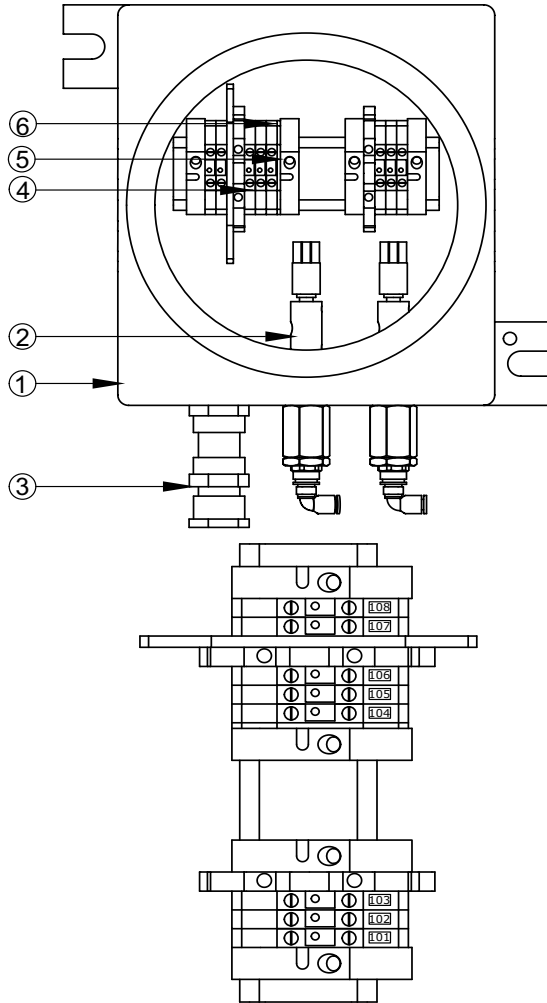

ITEM	DESCRIPTION	QTY
1	MIU dT HOUSING FOR PV-US PURGE SYSTEM	1
2	EXPLOSION PROOF SPCO PNEUMATIC SWITCH	2
3	GLAND EEx d,BRASS SIZE 1/2"NPT	1
4	WDU 2.5 TERMINAL	8
5	EARTH TERMINAL WPE 2.5	2
6	PARTITION FOR NON-INCENDIVE SEPARATION	1

SOLENOID VALVE
CONNECTION VIA
CABLE ENTRY.

VENTILATION
COMPLETE
PNEUMATIC SWITCH
(2 barg / 30 psi /
200Kpa)
UL, CSA & IEC: 6A
125Vac / 3A 250Vac

VENTILATION IN
PROGRESS
PNEUMATIC SWITCH
(2 barg / 30 psi /
200Kpa)
UL, CSA & IEC: 6A
125Vac / 3A 250Vac

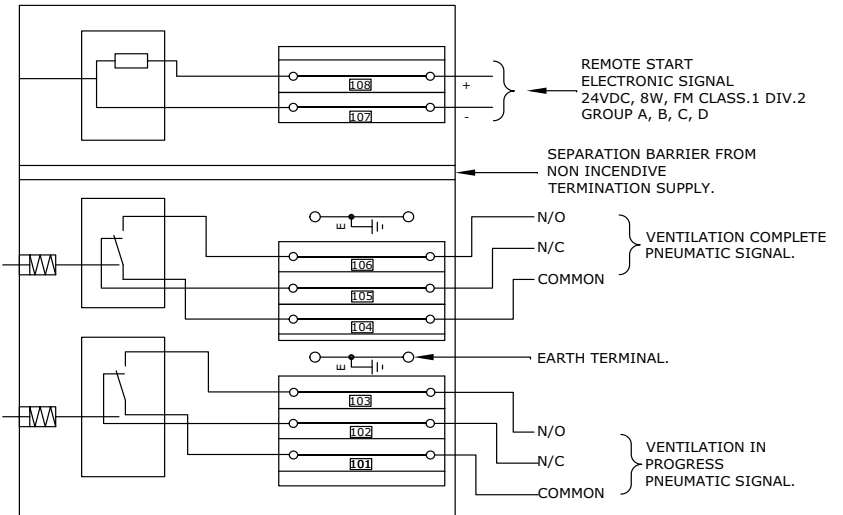

APPD	JPdB	ISSUE:	01				MATERIAL
		MOD. No:	DRAWN				
CHK'D	MH	DATE:	17/01/2019				FINISH
DR'WN	LG	APPROVED:	JPdB				
DRAWING STATUS: RELEASED							

Expo Technologies Limited SURREY TW16 5DB
UNITED KINGDOM

TITLE
PRE-VENTILATION PO SYSTEM TERMINAL LAYOUT

JOB No:

CUSTOMER:

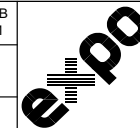

SCALE

DRAWING No.

AGE-WC00-273

SHEET No. 1 OF 1

3rd ANGLE PROJECTION

DIMENSIONS IN mm
DO NOT SCALE

UNSPECIFIED NO DEC PLACE ±0.5
TOLERANCES 1 DEC PLACE ±0.2
2 DEC PLACE ±0.1
FLATNESS TO BE LESS THAN 0.4mm OVER ANY 100mm LENGTH

The contents of this drawing / document are Copyright © Expo Technologies Limited. They are to be treated as confidential and are returnable upon request. They are not to be copied or communicated in part or in whole without written consent from Expo Technologies Limited, neither are they to be used in any way against our interests.

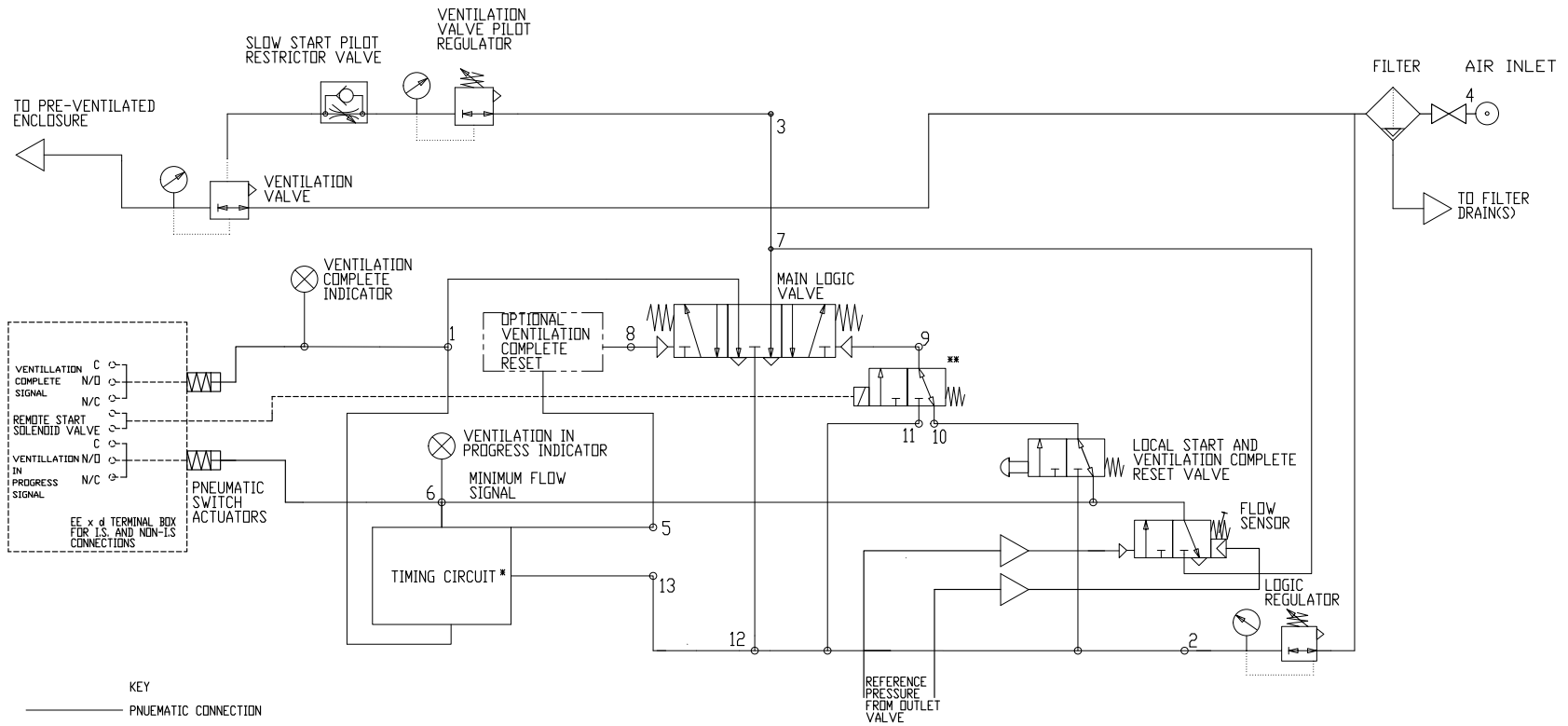

CIRCUIT DIAGRAM FOR PV PO SYSTEM
ALTERNATE CONFIGURATION

*TIMING CIRCUIT CAN EITHER BE MECHANICAL TIMER 'MT', ELECTRONIC TIMER TYPE 'ET' OR PNEUMATIC TIMER 'PT'. VENTILATION COMPLETE SIGNAL WILL BE EITHER SIGNAL FROM ELECTRONIC TIMER OR FROM PNEUMATIC/MECHANICAL TIMER.

**REMOTE START AND VENTILATION COMPLETE RESET VALVE (OPTIONAL) IF NOT FITTED 9 AND 10 TO BE CONNECTED AND 11 TO BE PLUGGED

*** RESTRICTORS AND QUICK EXHAUST VALVES MAY BE ADDED TO BALANCE TIMING ON THE VALVES

APPD	JPdB	ISSUE:	1				
		MOD. No:	DRAWN				
CHKD	JPdB	DATE:	29/11/2018				
		APPROVED:	JPdB				
DRWN	LG	DRAWING STATUS:	CERT RELATED				

MATERIAL	
FINISH	

Expo Technologies Limited SURREY TW16 5DB UNITED KINGDOM	
TITLE PRE-VENTILLATION PO SYSTEM SCHEMATIC	
JOB No:	CUSTOMER:

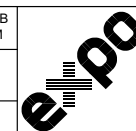

SCALE	-
DRAWING No.	AGM-PA00-152
SHEET No.	1 OF 1

8	7	6	5	4	3	2	1
3RD ANGLE PROJECTION	DIMENSIONS IN mm [] DENOTES IMPERIAL	TOLERANCES UNLESS OTHERWISE STATED FLATNESS TO BE LESS THAN 0.4 OVER ANY 100mm LENGTH	DO NOT SCALE IF IN DOUBT ASK				
		DECIMALS X±0.5 X±0.1 X.XX±0.1 X.XXX±0.05					
		ANGLE STD ±1°					

ITEM	DESCRIPTION	QTY
1	STAINLESS STEEL JUNCTION BOX EJB21-UL-INX	1
2	CABLE GLAND CLASS 1 DIV 2 1/2" NPT	1
3	12 SERIES PRESSURE SWITCH, SPDT - 5A	2
4	TERMINAL RAIL - 150mm LONG	1
5	END BRACKET	4
6	EARTH TERMINAL WPE 2.5	2
7	WDU 2.5 TERMINAL	8

The contents of this drawing / document are Copyright © Expo Technologies Limited. They are to be treated as confidential and are returnable upon request. They are not to be copied or communicated in part or in whole without written consent from Expo Technologies Limited, neither are they to be used in any way against our interests.

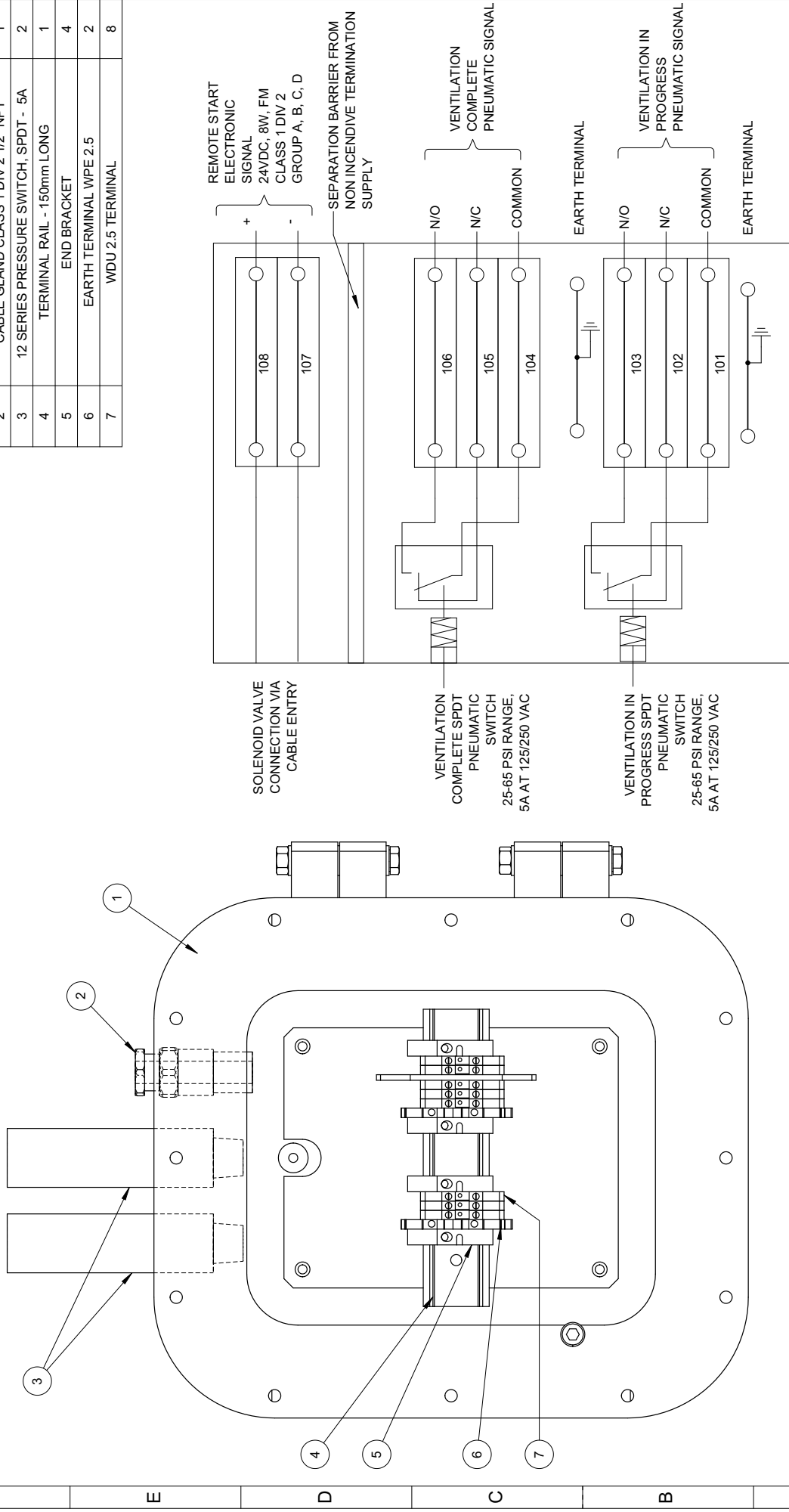

REVISION	MOD No.	DATE	DRAWN	CHECKED	APPROVED	DRAWN DATE	CONTROLLED MATERIAL	WEIGHT (kg)	Expo Technologies Limited SURREY TW16 5DB UNITED KINGDOM	DRAWING No.
01	23106	10/07/2023	PB	AW	TH	26/04/2023		-	AGE-WC00-340	
A		26/04/2023	PB	AW	TH	RELEASED	01		3PV 5PV 4X US OPTION TERMINAL LAYOUT	
						SCALE	A3			
										SHEET No. 1 OF 1



8	3RD ANGLE PROJECTION								1
7	DIMENSIONS IN mm [] DENOTES IMPERIAL								2
6	TOLERANCES UNLESS OTHERWISE STATED FLATNESS TO BE LESS THAN 0.4 OVER ANY 100mm LENGTH	DECIMALS	ANGLE						3
5	DO NOT SCALE IF IN DOUBT ASK	X±0.5	STD ±1°						4
4		X±0.1							5
3		X±0.1							6
2		X±0.05							7
1									8

SWITCH-INDICATOR SEQUENCE DIAGRAM FOR PRESTART VENTILATION SYSTEMS

AIR ON (NO VENTILATING)

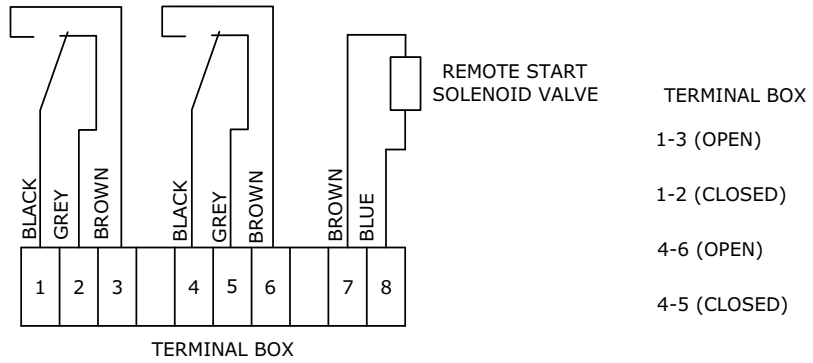
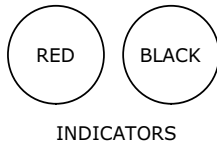

DURING VENTILATION

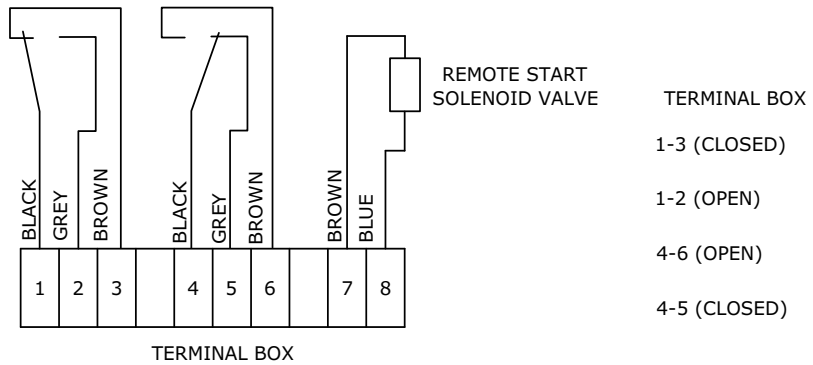
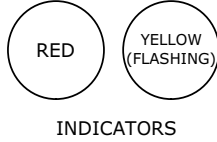

VENTILATION COMPLETE - NORMAL OPERATION

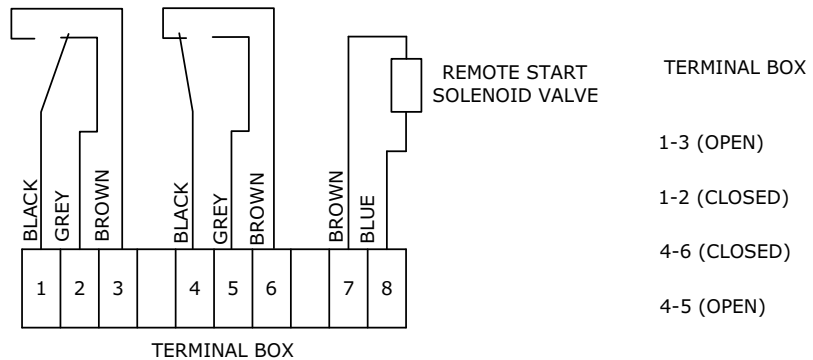
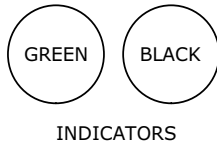

DRAWING No.		SD8100		SHEET No. 1 OF 1	
WEIGHT (kg)		TITLE		INDICATOR DISPLAYS/SWITCH SEQUENCE	
MATERIAL		FINISH		SCALE	
DRAWN DATE		DRAWING STATUS		REVISION	
05/06/2013		MH		03	
CE		AR		MLC	
DATE		CHECKED		APPROVED	
11/05/20		MN		MP	
24/10/13		CB		MP	
05/06/13		CB		MP	
MOD #		DRAWN		SCALE	
D04-12436		CE		N.T.S	
5862		CB		A3	
DRAWN		DATE		CERT REL	
05/06/13		03		03	
REVISION		MOD #		DRAWN	
03		D04-12436		05/06/13	
02		5862		24/10/13	
01		DRAWN		05/06/13	



EU Declaration of Conformity



This declaration of conformity is issued under the sole responsibility of the manufacturer and EU authorised representative named above:

Object of the declaration:

Product Name:	Pre-Start Ventilation Systems (PV Systems)
Product Options:	This declaration covers all variants associated with the above product

The object of the declaration described above is in conformity with the relevant Union harmonization legislation:

Type of Legislation:	
	Electromagnetic Compatibility Directive (EMC) 2014/30/EU
	ATEX Directive 2014/34/EU

The following harmonised standards and technical specifications have been applied:

Type of Legislation:	General Standard:	Reference Standard:
EMC Directive:	Generic standards – Immunity for industrial environments	EN 61000-6-2:2005
	Generic standards – Emission standard for industrial environment	EN 61000-6-4:2007
ATEX Directive:	Equipment general requirements	EN IEC 60079-0:2018
	Equipment protection by flameproof enclosures "d"	EN 60079-1:2014
	Equipment protection by increased safety "e"	EN IEC 60079-7:2015+A1:2018
	Equipment protection by intrinsic safety "i"	EN 60079-11:2012
	Equipment protection by encapsulation "m"	EN 60079-18:2015+A1:2017

Notified Body:

NB Name:	ExVeritas
NB Number:	2804

Technical documentation and assessments are in the Expo Technologies confidential technical file SC024.

For and on behalf of Expo Technologies Ltd.



John Paul De Beer
Managing Director

Date: 3rd June 2024

EU Declaration of Conformity



This declaration of conformity is issued under the sole responsibility of the manufacturer and EU authorised representative named above:

Object of the declaration:

Product Name:	MiniPurge Interface Units (MIU/e)
Product Options:	This declaration covers all variants associated with the above product

The object of the declaration described above is in conformity with the relevant Union harmonization legislation:

Type of Legislation:
ATEX Directive 2014/34/EU

The following harmonised standards and technical specifications have been applied:

Type of Legislation:	General Standard:	Reference Standard:
ATEX Directive:	Equipment general requirements	EN IEC 60079-0:2018
	Equipment protection by increased safety "e"	EN 60079-7:2015+A1:2018
	Equipment dust ignition protection by enclosure "t"	EN 60079-31:2014

Notified Body:

NB Name:	ExVeritas
NB Number:	2804

Technical documentation and assessments are in the Expo Technologies confidential technical file SC027.

For and on behalf of Expo Technologies Ltd



John Paul De Beer
Managing Director

Date: 7th May 2024

EU Declaration of Conformity



This declaration of conformity is issued under the sole responsibility of the manufacturer and EU authorised representative named above:

Object of the declaration:

Product Name:	Electronic Timer Module (ETM-IS**_***)
Product Options:	This declaration covers all variants associated with the above product

The object of the declaration described above is in conformity with the relevant Union harmonization legislation:

Type of Legislation:
ATEX Directive 2014/34/EU

The following harmonised standards and technical specifications have been applied:

Type of Legislation:	General Standard:	Reference Standard:
ATEX Directive:	Equipment general requirements	EN IEC 60079-0: 2018
	Equipment protection by intrinsic safety "i"	EN 60079-11: 2012

Notified Body:

NB Name:	ExVeritas
NB Number:	2804

Technical documentation and assessments are in the Expo Technologies confidential technical file SC039.

For and on behalf of Expo Technologies Ltd



John Paul De Beer
Managing Director

Date: 7th May 2024

[This Page Intentionally Left Blank]

Expo Technologies Ltd.

Expo Technologies Ltd.
Unit 2 The Summit, Hanworth Road
Sunbury-on-Thames,
TW16 5DB, UK
T : +44 20 8398 8011
E : sales@expoworldwide.com

EU-Authorised Representative

Expo Pharma Engineering
Unit 46, Eastgate Drive
Little Island, Co. Cork
T45 WR6, Ireland
E : euar@expopharma.ie

Expo Technologies Inc.

Expo Technologies Inc.
9140 Ravenna Road Unit #3
Twinsburg,
OH 44087, USA
T: +1 440 247 5314
E: sales.na@expoworldwide.com

Expo Technologies China

Qingdao Expo M&E Technologies Co. Ltd
617 Shilin Er Lu
Jimo District, Qingdao,
266200, China
T: +86 532 8906 9858
E: qingdao@expoworldwide.com

www.expoworldwide.com